



PROFESSIONALS AT WORK

**CRI-MAN**®



EN

GENERAL CATALOGUE



### The company



page 4

### Philosophy



page 5

### Research & Development



page 6



### Livestock slurry management



page 12-13

### Pumps



PTS  
page 14



PTE  
PTC  
page 15



ETO/ETV  
ETO/EPO  
page 16



PTS/PTE  
PTH  
page 17



### Biogas plants



page 24-25

### Pumps



PTS  
PLD  
page 26



ETO/ETV  
ETO/EPO  
page 27



### Mixers



BMC  
MXP  
page 28



### Waste water treatment



page 36-37

### Pumps



ETO/ETV  
ETO/EPO  
page 38



PTS  
ER  
page 39

### Mixers

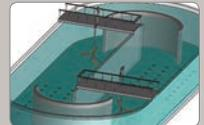

Mixing tanks  
page 40

# INDEX

## Main strengths



Pumps page 7



Mixers page 8



Separators page 9

## Plants installed



page 10

## Sales organization



page 11

CRI-MAN

## Mixers



PTD  
PTO/PTF  
page 18



TBM  
TBX  
page 19



Sistemi  
a labirinto  
page 20

## Separators



SM  
page 21-22

## Plants installed



page 23

LIVESTOCK



TBM  
AF  
page 29



MXB  
MXL  
page 30



Mixer  
accessories  
page 31

## Separators



SM  
page 32-33

## Plants installed



page 34-35

BIOGAS



TBM  
AF  
page 41



TBX  
MXV  
page 42

## Aerators



SMO  
OXIGET  
page 43

## Separators



SM  
page 44-45

## Other applications



page 46

## Plants installed



page 47

INDUSTRY

# The company

## Dedicated technology for processing livestock slurry, biogas, and civil/industrial effluents

We design and construct machines for the processing of livestock slurry, biogas, and civil/industrial effluents. Thirty year's experience, first in the processing of livestock slurry, and then extending with time into the biogas and industrial sectors, enables us to provide our customers with an extremely Reliable and Professional Service.

Our flagship products are our separators, chopper pumps, and mixers.

Our products are manufactured entirely at our sites in Correggio (Reggio Emilia, Italy).

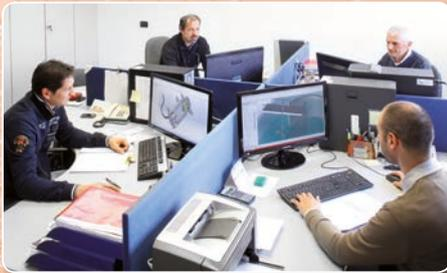

# Philosophy

Based on our extended experience and detailed studies of our customers in the effluent treatment sector in general, we strive to fully comprehend our customers' needs, using this as the starting point and guiding principal for the operating methods that permeate all our company activities.

Our Vision is for Professionalism and Reliability in all relations with our customers.

Our Mission is to transform this commitment into operative reality.

The CRI-MAN organization exists in order to fulfil these aims, which are achieved by close attention to the surrounding environment.

This approach is certified by the Quality Management Systems UNI EN ISO 9001:2008 and UNI EN ISO 14001:2004, which emphasise the two aspects that we hold most dear:

- Customer Satisfaction
- Guaranteeing Environmental Sustainability.



# Vision

## Professionalism and Reliability... through time

Product  
innovation

On-time  
delivery

Technical  
assistance

Extended product  
durability

Technical  
know-how

# Mission



# Research & Development

## Professionalism and Reliability underlying every project

In our projects we place our customers in the leading role, or more specifically, their individual needs. We start by listening very carefully to their real requirements, which become the guiding principles for each project.

In the resulting dialogue there is a convergence of ideas, experience, and know-how allowing the creation of products made-to-measure for each customer, with particular care dedicated to minimizing the consumption of energy and water resources, in full compliance with environmental regulations.

CRI-MAN make available their experience and technological know-how for the development of products that satisfy all the requirements of reliability, flexibility, strength, and durability.

To round off our Vision/Mission, it is worth underlining our strong points in machine performance:

- our comprehensive range makes it possible to offer total solutions, in particular as regards processing livestock slurry
- high efficiency, which translates into low energy consumption

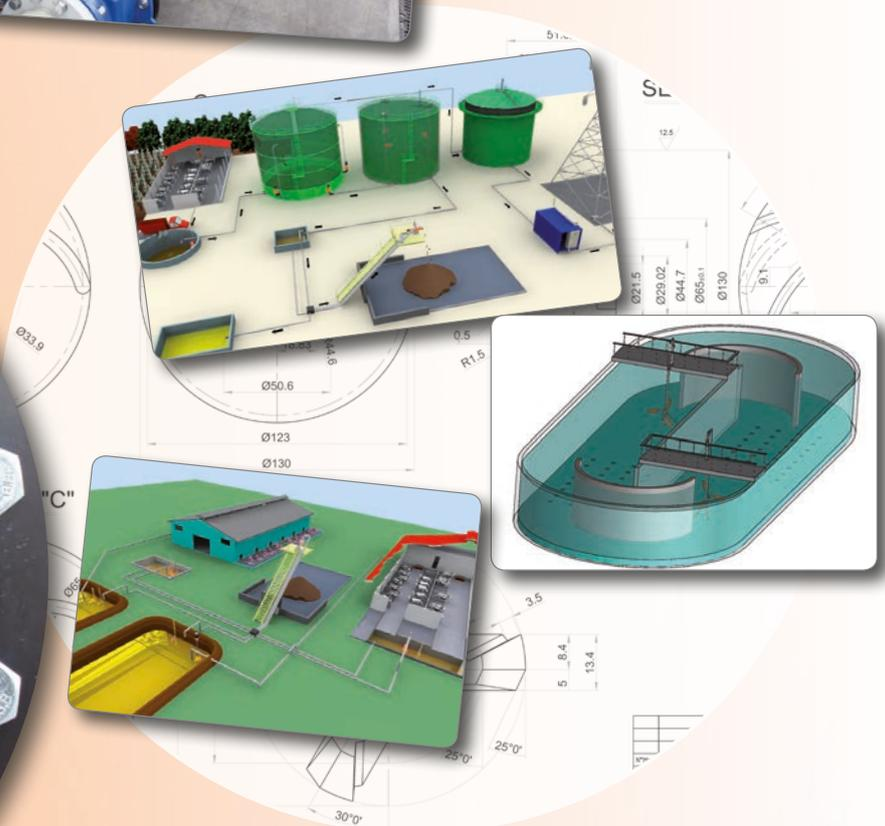
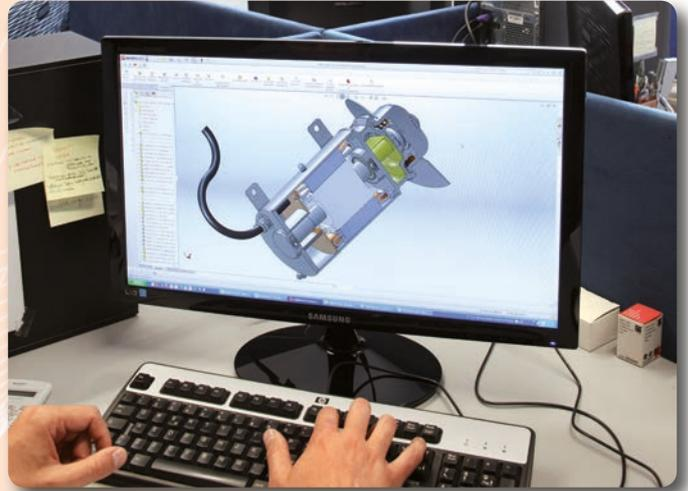



# Main strengths: Pumps



**CRI-MAN**

**Double Chopping System**

The first chopping system is composed of two blades made of chrome steel, fixed on the body inlet, that work against a spiral conveyor made from high grade cast iron and is fitted to the motor shaft. Both materials have undergone a specific treatment for hardening. In a pump with a speed of 1750 rpm, the only first chopping system operates at over 170 cuts per second!

The second chopping system is composed of a shear cutting plate of special high grade cast iron that works against the impeller, also in high grade cast iron, blades with sharp profile. Both materials have undergone a specific treatment for hardening.

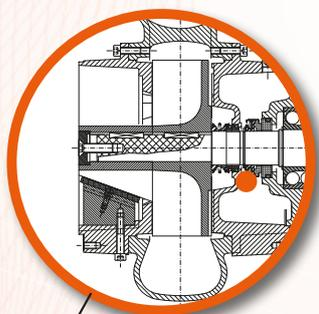

**Double mechanical seal**  
Mechanical seals in silicon carbide and graphite-Ceramics.



**Thermal probe sensors**

Double thermal probes, immersed in the stator, to prevent overheating of the electric motor and to preserve the operational life span of the motor.

**High hydraulic efficiency**

Hydraulics designed to correlate high Efficiency (up to 77%) with high chopping and anti-clogging performances. Data according to UNI EN ISO 9906 Standard.

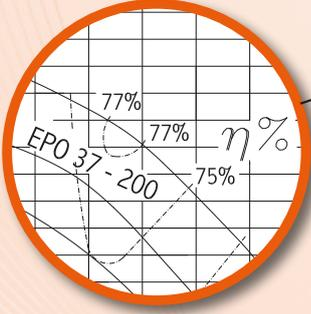
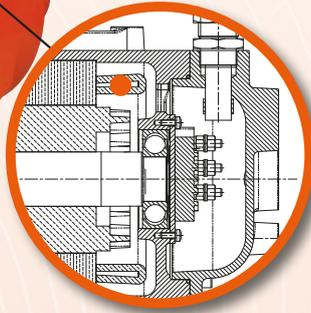

**Range of accessories**

Wide range of accessories for every type of pump installation.

**Humidity probe (on request)**

Humidity probe installed in the oil chamber to prevent damages in case of leakage.

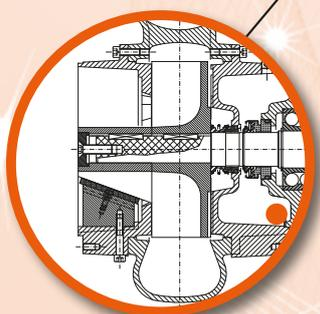

**The Best Choice**



# Main strengths: Mixers

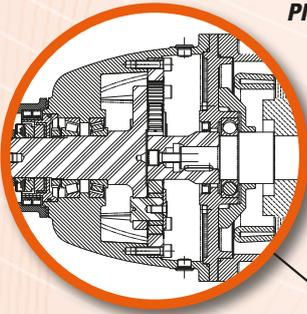

### **Planetary gearbox (TBM Series only)**

Reduced energy consumption and longer gear life.

### **High axial thrust efficiency**

Electric motor, mechanical components and propeller profile designed to achieve high efficiency in terms of axial thrust and low energy consumption.

Data according to ISO 21630 Standard.

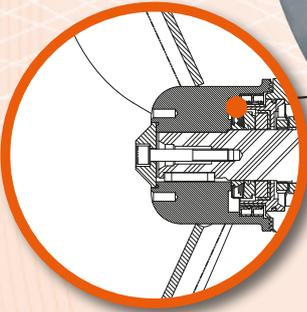
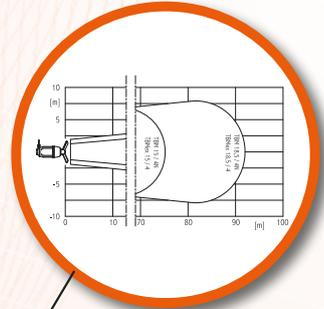

### **Double sealing system**

Sealing system composed of two lip seals on ceramic bushing (TBM Series only) and tungsten carbide mechanical seal.

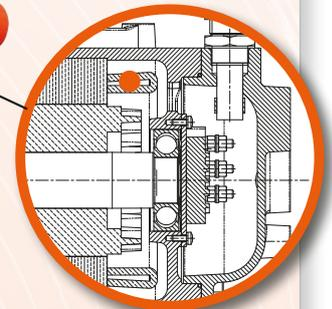
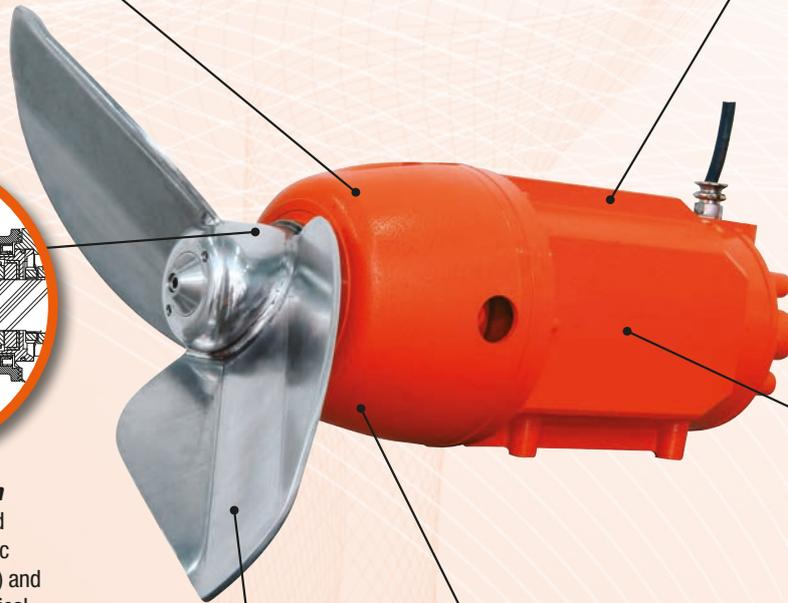

### **Thermal probe sensors**

Double thermal probes, immersed in the stator, to prevent overheating of the electric motor and to preserve the operational life span of the motor.

### **Self-cleaning propeller**

Propeller in stainless steel with self-cleaning profile.

### **Range of accessories**

Wide range of accessories for every type of mixer installation.

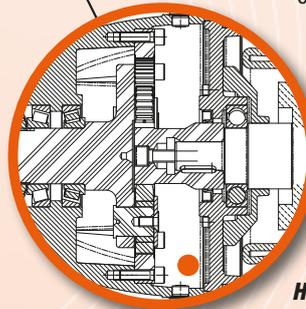

### **Humidity probe (on request).**

Humidity probe installed in the gear box to prevent damages in case of leakage.



The Best  
Choice



# Main strengths: Separators



**Screw treatment**  
Innovative coating treatment with mixtures of tungsten carbide and metallic matrix which ensures very high hardness and low brittleness.



**Screens**  
Stainless steel screens with geometrical structure, strength and material chemical composition specifically designed for each application.



**Screen inspection window**  
Top inspection window for easy and quick check of screen cleaning.



**Planetary gearbox**  
Reduced energy consumption and longer gear life.

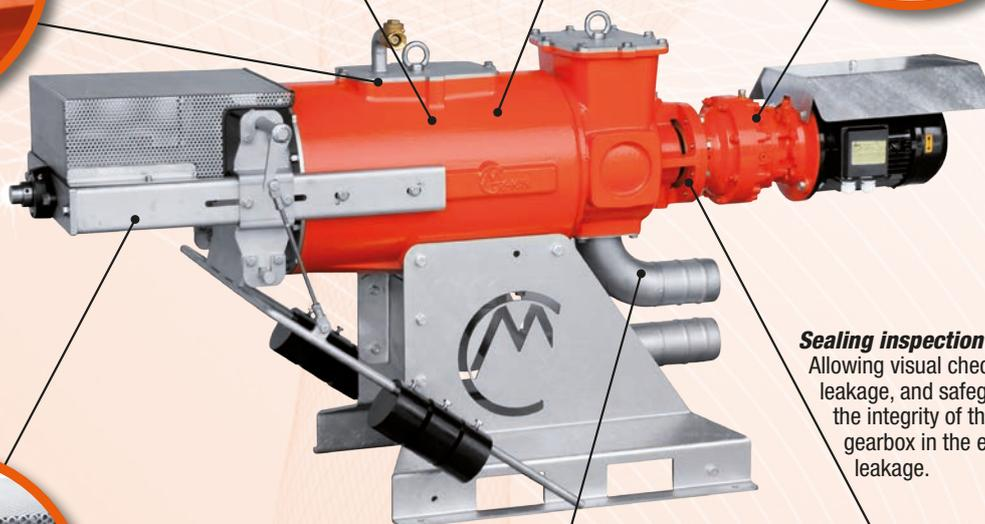

**Sealing inspection window**  
Allowing visual check for leakage, and safeguarding the integrity of the gearbox in the event of leakage.



**Front side supported screw**  
Front bearing structure for a perfect guide of the screw which reduces the wearing on the screen.

**Sealing system**  
System of three lip seals with grease for a secure sealing between the separator and the gearbox.



**Smart Piping input**  
Inlet piping designed to leave them empty, and avoid the possible freezing, during the inactivity of the machine.



# Fields of use

Our experience in **the livestock sector** dates back to the end of the 1970s, when the founders of the company CRI-MAN, subsequently established in 2001, worked in the livestock barn equipment sector.

This in-depth knowledge of the real needs of customers was later invaluable for the development of solutions that reduce the work of livestock farmers in the processing of slurry.

Over the years the technology constantly improved, with an emphasis on the reliability of the developed designs.

Today CRI-MAN are able to offer, in the livestock slurry processing sector, extremely reliable turnkey solutions. This is on the strength of our vast range of equipment, with hundreds of machine and accessory models available.



From its earliest years of operation, CRI-MAN have always dedicated attention to the world of **biogas**, designing and constructing machines and accessories for substrate handling in biogas plants.

Today CRI-MAN are well known among operators in the biogas sector as professional partners who offer a full and reliable range of products.

Thousands of CRI-MAN machines are installed in biogas plants throughout the world.



In the civil and **industrial effluent treatment sector** we are well aware of competing alongside multinationals armed with a considerable "firepower" both in terms of resources and available products.

However, perhaps precisely this difference in scale enables us to offer highly competitive and versatile solutions which at the same time do not cut corners on quality and reliability of products, all of which are designed to handle extremely demanding conditions.

Like the biogas sector, again CRI-MAN have thousands of machines installed in waste water treatment plants worldwide.



# Sales Organization

The technical capability to adapt your products to the needs of various different markets, combined with an efficient internal organization, ensures you are competitive in the international scenario.

CRI-MAN export up to 80% abroad through a network of selected distributors who guarantee an excellent Customer Service.



CRI-MAN

## Customer Service

### Original Cri-Man spare parts

Choosing original parts means protecting the efficiency of your plants and extending their useful life.

All original CRI-MAN spares are totally compatible because they are made to integrate perfectly into our machines.

### [www.cri-man.com](http://www.cri-man.com)

A website designed to provide a complete instrument for communicating with users and retailers, always up to date with the latest news and providing all the necessary technical information, available directly or for downloading if confidential in nature.





# Livestock slurry management

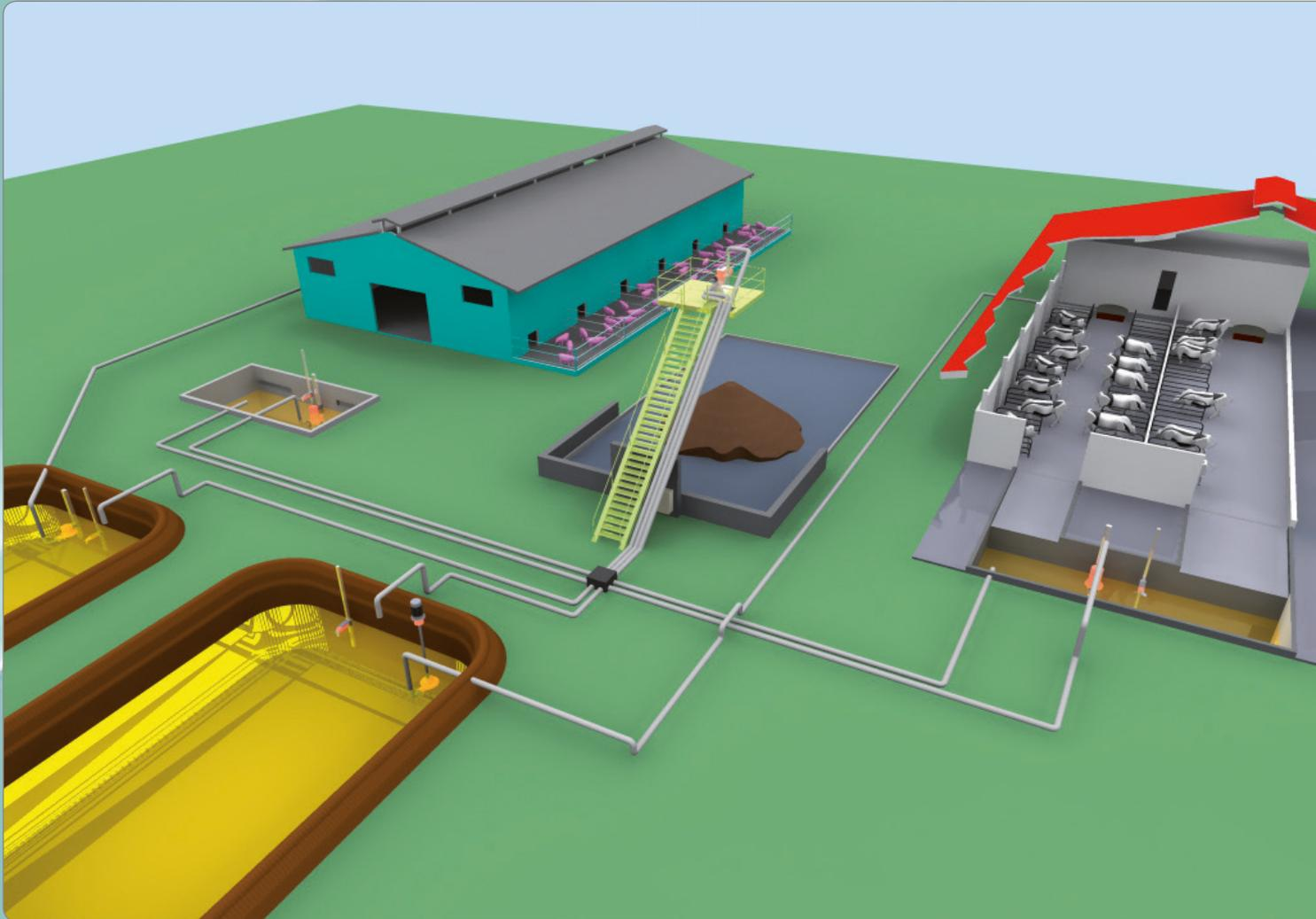

The best way to explain the operation of a slurry livestock system is to describe an actual plant located near the CRI-MAN factory. Farming with 80 dairy cows and 1500 fattening pigs. The slurry treatment installation, completed in 2004, is controlled by a control panel and a pneumatic valves system, which runs centrally and automatically the both cow and pig slurry.

The installation features are:

- **the complete automation** of the separation system and slurry mixing, through mixers, pumps and pneumatic valves, controlled by a central control panel
- the presence of a single separator, which treats the slurry coming from both cattle sheds, by **always keeping separated the cow slurry from the pig slurry**

The installation can be divided into:

## Cow slurry flushing and separation

In the cow slurry storage tank there is a PTE 11- 250 vertical pump equipped with 11 kW which is used with two retractable flushing valves to flush the cow passages. The slurry is collected into a

pre-tank, mixed by a TBM 5,5/4N mixer with 5,5 kW motor, then pumped up to the separator by a PTS 5,5-100 pump with 5,5 kW motor.

The solid fraction is utilized for composting, whereas the liquid fraction is sent to the storage tank.

## Pig slurry flushing and separation

In the pig slurry storage tank there is a PTS 4-100 pump with 4 kW motor, which pumps the slurry into the pigsty, where we have the "flushing" through a "Lusetti system" flooring.

The slurry is collected into pre-tank, mixed by a TBM 4/4 mixer with 4 kW motor, then pumped up to the separator by a PTS 4-100 pump with 4 kW motor.

The solid fraction of separated slurry is utilised for composting, whereas the liquid fraction is sent to the storage tank.

## Operation and control system

A control panel and a pneumatic valves system automatically control the whole installation, without mixing cow slurry with pig slurry.



**LIVESTOCK**



Check on video



# Pumps

## PTS 40 SERIES

*Submersible chopper pump*

**Technical specifications:**

- Chopping system
- Max capacity: 26 m<sup>3</sup>/h 114 US gpm
- Head: 17 m 56 ft
- Motor power: 0,75 - 1,1 kW 1 - 1,5 HP
- Suction: 65 mm 2 9/16 inches
- Discharge: 40 mm 1 9/16 inches



## PTS 80 SERIES

*Submersible chopper pump*

**Technical specifications:**

- Chopping system and anti-clogging screw
- Max capacity: 160 m<sup>3</sup>/h 705 US gpm
- Head: 46 m 151 ft
- Motor power: 2,2 - 18,5 kW 3 - 26 HP
- Suction: 100 mm 4 inches
- Discharge: 80 mm 3 1/8 inches



## PTS 100-150 SERIES

*Submersible chopper pump*

**Technical specifications:**

- Double chopping system
- Max capacity: 340 m<sup>3</sup>/h 1497 US gpm
- Head: 21 m 69 ft
- Motor power: 4 - 18,5 kW 5,4 - 26 HP
- Suction: 150 - 200 mm 6 - 8 inches
- Discharge: 100 - 150 mm 4 - 6 inches

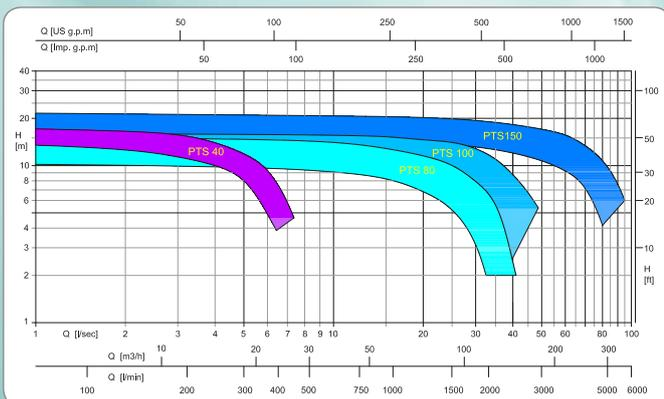

## PTE / PTEM SERIES

*PTE vertical chopper pump with electric motor*  
*PTEM version with adjustable mixing nozzle*

### Technical specifications:

- Double chopping system
- Max capacity: 340 m<sup>3</sup>/h 1497 US gpm
- Head: 53 m 174 ft
- Motor power: 4 - 30 kW 5,4 - 42 HP
- Suction: 150 - 200 mm 6 - 8 inches
- Discharge: 100 - 150 mm 4 - 6 inches

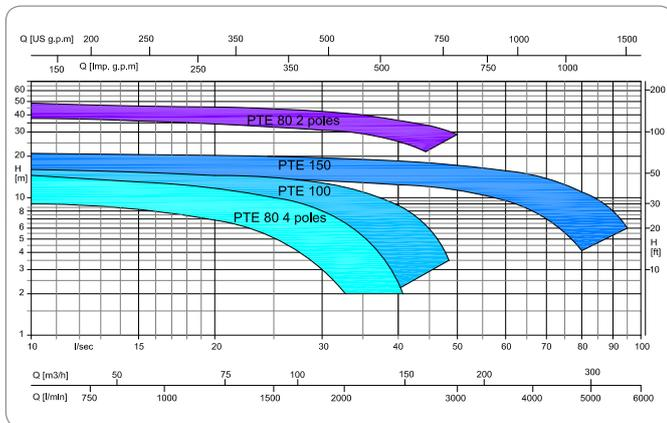

LIVESTOCK

## PTC / PTCM SERIES

*PTC vertical chopper pump with overgear for tractors*  
*PTCM version with adjustable mixing nozzle*

### Technical specifications:

- Double chopping system
- Max capacity: 550 m<sup>3</sup>/h 2422 US gpm
- Head: 51 m 167 ft
- Tractor rated power: 40 - 95 kW 54 - 127 HP
- Suction: 150 - 200 mm 6 - 8 inches
- Discharge: 100 - 150 mm 4 - 6 inches

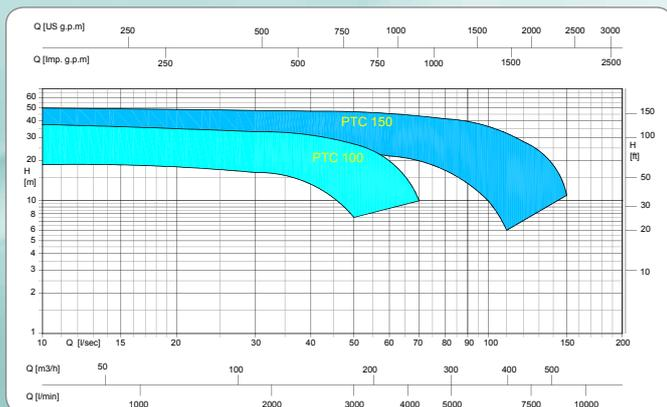



# Pumps

## ETO/ETV SERIES

### Horizontal electric chopper pump

#### Technical specifications:

- Double chopping system
- Max capacity: 340 m<sup>3</sup>/h 1497 US gpm
- Head: 105 m 345 ft
- Motor power: 0,75 - 45 kW 1 - 60 HP
- Suction: 65 - 200 mm 2 9/16 - 8 inches
- Discharge: 40- 150 mm 1 9/16 - 6 inches

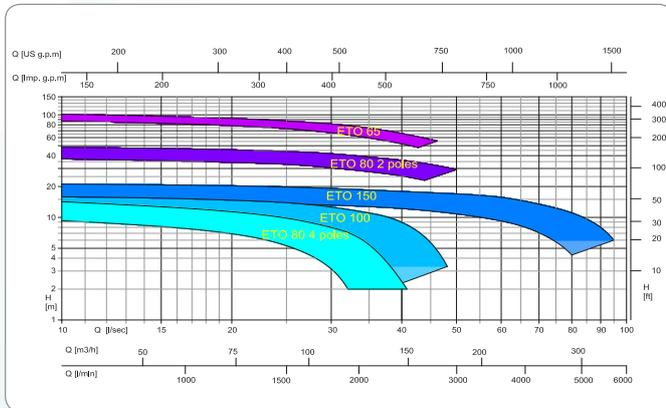

## ETO 200 / EPO 200 SERIES

### Horizontal electric chopper pump

#### Technical specifications:

- ETO version: double chopping system
- EPO version: single chopping system
- Max capacity: 800 m<sup>3</sup>/h 3523 US gpm
- Head: 22 m 72 ft
- Motor power: 22 - 65 kW 29 - 87 HP
- Suction: 250 mm 10 inches
- Discharge: 200 mm 8 inches

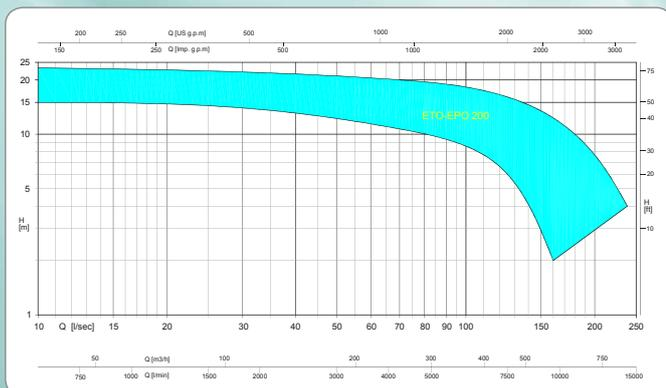

## PTS 250 / PTE 250 SERIES

*PTS 250 Submersible pump for Flushing*

*PTE 250 Vertical pump with external electric motor for Flushing*

### Technical specifications:

- |                 |                        |             |
|-----------------|------------------------|-------------|
| • Max capacity: | 1080 m <sup>3</sup> /h | 4756 US gpm |
| • Head:         | 16 m                   | 52 ft       |
| • Motor power:  | 11 - 30 kW             | 15 - 40 HP  |
| • Suction:      | 250 mm                 | 10 inches   |
| • Discharge:    | 250 mm                 | 10 inches   |

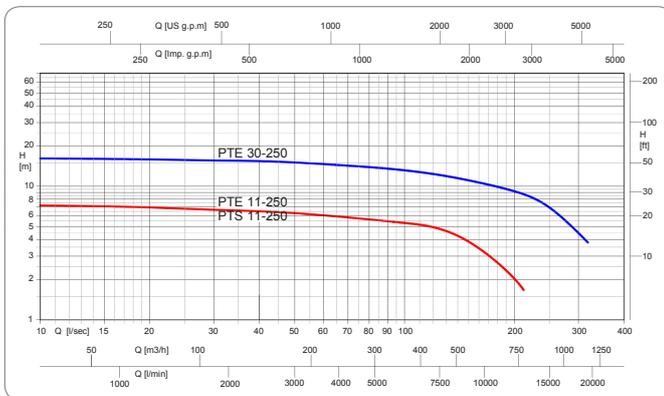

PTE 250



LIVESTOCK

## PTH SERIES

*Horizontal chopper pump with overgear for tractors*

### Technical specifications:

- |                          |                       |                   |
|--------------------------|-----------------------|-------------------|
| • Double chopping system |                       |                   |
| • Max capacity:          | 460 m <sup>3</sup> /h | 2026 US gpm       |
| • Head:                  | 155 m                 | 508 ft            |
| • Tractor rated power:   | 40 - 140 kW           | 54 - 188 HP       |
| • Suction:               | 100 - 150 mm          | 4 - 6 inches      |
| • Discharge:             | 65 - 100 mm           | 2 9/16 - 4 inches |

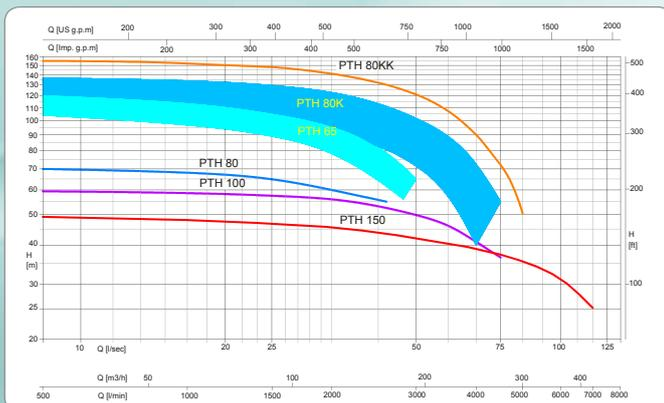



# Pumps

## PTD SERIES

*Horizontal chopper pump with overgear for Diesel engine*

**Technical specifications:**

- Double chopping system
- Max capacity: 460 m<sup>3</sup>/h      2026 US gpm
- Head: 138 m      453 ft
- Diesel engine power: 40 - 120 kW      50 - 161 HP
- Suction: 100 - 150 mm      4 - 6 inches
- Discharge: 65 - 100 mm      2 9/16 - 4 inches

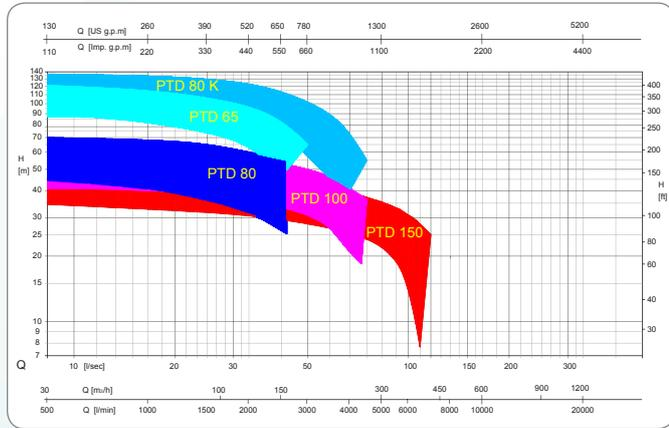

## PTO/PTF SERIES

*PTO Horizontal chopper pump with coupling for Diesel engines and electric motors*

*PTF Horizontal chopper pump with standard SAE housing*

**Technical specifications:**

- Double chopping system
- Max capacity: 460 m<sup>3</sup>/h      2026 US gpm
- Head: 138 m      453 ft
- Motor power: 40 - 120 kW      50 - 161 HP
- Suction: 100 - 150 mm      4 - 6 inches
- Discharge: 65 - 100 mm      2 9/16 - 4 inches

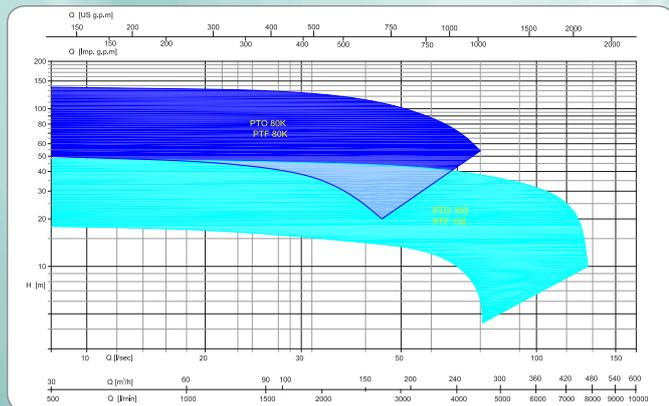

# Mixer

## TBM SERIES

### Submersible horizontal mixer

#### Technical specifications:

- Planetary gearbox
- Blades in stainless steel with self-cleaning profile
- Rpm: 350 - 900 (50Hz) 420 - 1080 (60Hz)
- Motor power: 1,5 - 18,5 kW 2 - 26 HP
- Axial thrust: 230 - 3826 N 52 - 860 lb
- Capacity: 643 - 6884 m<sup>3</sup>/h 2831 - 30313 US gpm
- Max working temp: 40 °C 104 °F



LIVESTOCK

## TBX SERIES

### Stainless steel submersible horizontal mixer

#### Technical specifications:

- Made entirely in stainless steel
- Blades in stainless steel with self-cleaning profile

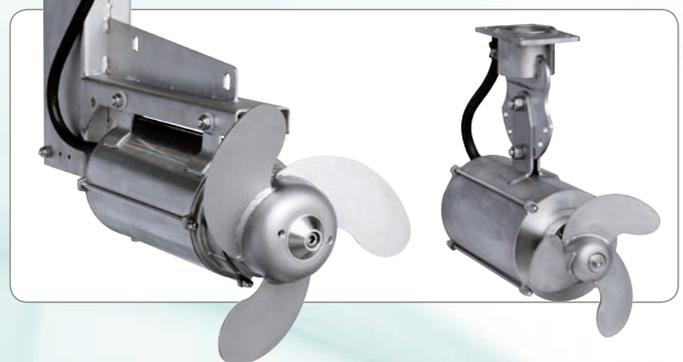
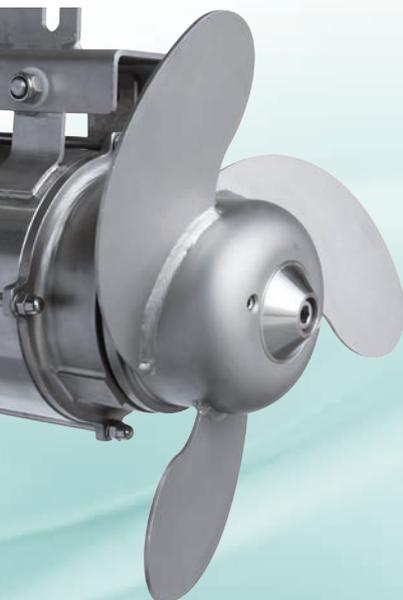

- Rpm: 1400 - 1900 (50Hz) 1680 - 2280 (60Hz)
- Motor power: 0,75 - 3 kW 1 - 4 HP
- Axial thrust: 117 - 373 N 25 - 84 lb
- Capacity: 279 - 1061 m<sup>3</sup>/h 1229 - 4672 US gpm
- Max working temp: 40 °C 104 °F



# Slalom systems

The Slalom system is a reasonable and economical way to store the slurry and use it when needed.

Thanks to the system, consisting of sluice gate and TBM mixer, is possible to keep the slurry in circulation while avoiding the formation of crusts.

The sluice gate, available in either galvanized steel or stainless steel AISI 304, can accommodate TBM mixers from 5,5 to 18,5 kW.

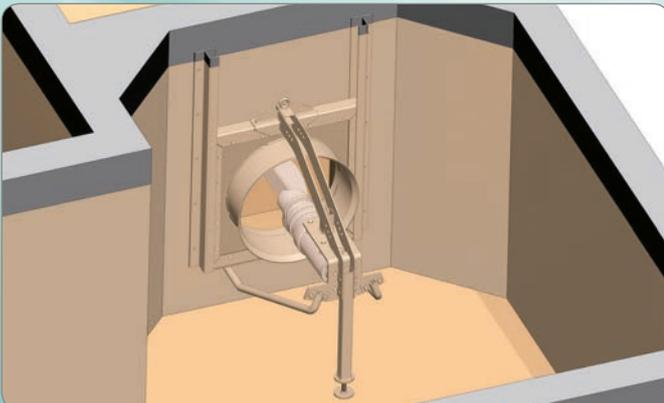
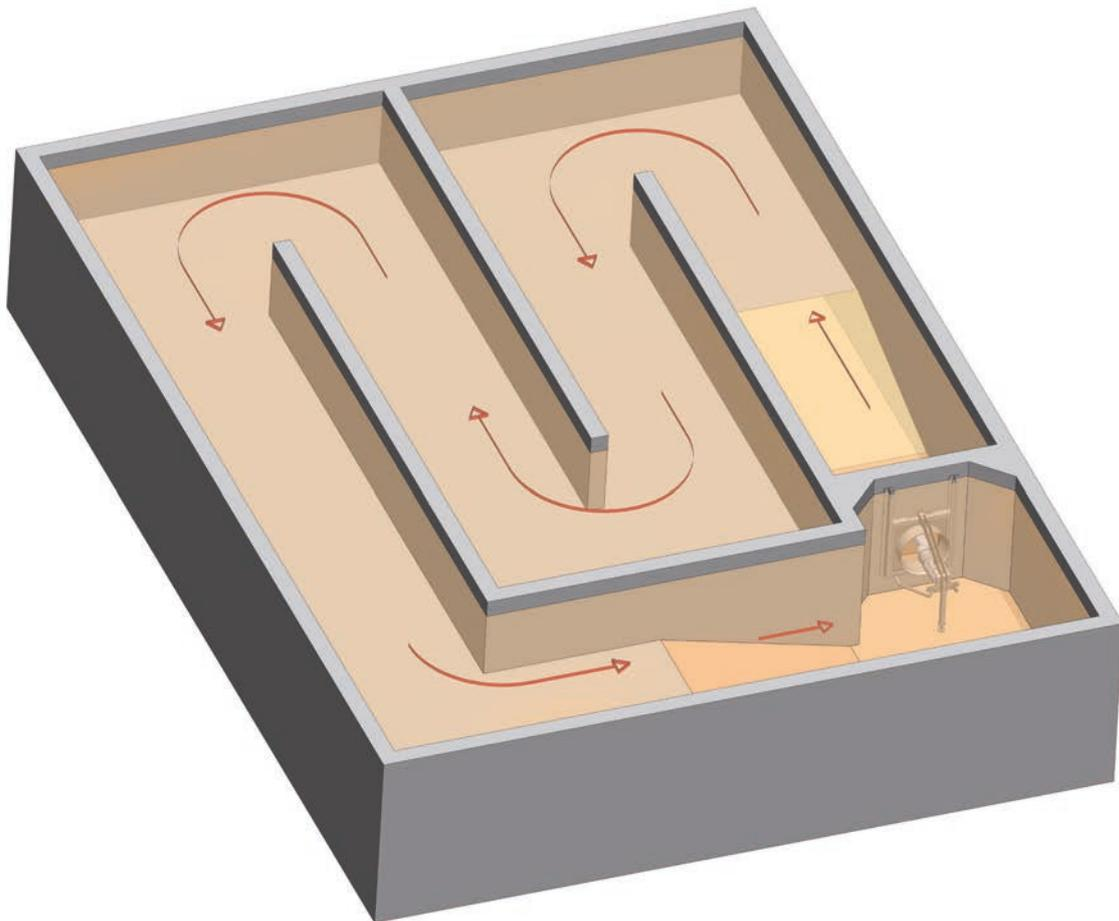

# Separators



## SM260 MINI SERIES

### Technical specifications:

- Screw in AISI 304 treated stainless steel
  - Standard Screen in AISI 316 stainless steel
  - Planetary gear box
  - Sealing system with three lip seals (mechanical seal on request)
- |                |                            |                    |
|----------------|----------------------------|--------------------|
| • Capacity:    | 4,5 - 18 m <sup>3</sup> /h | 20 - 79 US gpm     |
| • Rpm:         | 20 (50Hz)                  | 24 (60Hz)          |
| • Motor power: | 3 kW                       | 4 HP               |
| • Screen mesh: | 0,25 - 1 mm                | 0,01 - 0,04 inches |
- Up to 30% Dry Matter

For farms up to 300 cows



## SM260 BASIC SERIES

### Technical specifications:

- Screw in AISI 304 treated stainless steel
  - Standard Screen in AISI 316 stainless steel
  - Planetary gear box
  - Sealing system with three lip seals (mechanical seal on request)
- |                |                          |                    |
|----------------|--------------------------|--------------------|
| • Capacity:    | 4 - 50 m <sup>3</sup> /h | 18 - 220 US gpm    |
| • Rpm:         | 33 (50Hz)                | 40 (60Hz)          |
| • Motor power: | 4 kW                     | 5,4 HP             |
| • Screen mesh: | 0,25 - 1 mm              | 0,01 - 0,04 inches |
- Up to 30% Dry Matter

For farms from 300 - 800 cows



## SM260 PROFESSIONAL SERIES

### Technical specifications:

- Screw in AISI 304 treated stainless steel
  - Front side supported screw
  - Standard Screen in AISI 316 stainless steel
  - Planetary gear box
  - Sealing system with three lip seals (mechanical seal on request)
- |                |                          |                    |
|----------------|--------------------------|--------------------|
| • Capacity:    | 4 - 50 m <sup>3</sup> /h | 18 - 220 US gpm    |
| • Rpm:         | 33 (50Hz)                | 40 (60Hz)          |
| • Motor power: | 4 kW                     | 5,4 HP             |
| • Screen mesh: | 0,25 - 1 mm              | 0,01 - 0,04 inches |
- Up to 30% Dry Matter

For farms from 700 - 1200 cows and Biogas Plant.





# Separators

## SM300 PROFESSIONAL SERIES

### Technical specifications:

- Screw in AISI 304 treated stainless steel
  - Front side supported screw
  - Standard Screen in AISI 316 stainless steel (Heavy Duty screen on request)
  - Planetary gear box
  - Sealing system with three lip seals (mechanical seal on request)
- |                |                          |                    |
|----------------|--------------------------|--------------------|
| • Capacity:    | 6 - 72 m <sup>3</sup> /h | 26 - 317 US gpm    |
| • Rpm:         | 33 (50Hz)                | 40 (60Hz)          |
| • Motor power: | 5,5 kW                   | 7,4 HP             |
| • Screen mesh: | 0,25 - 1 mm              | 0,01 - 0,04 inches |
- Up to 30% Dry Matter

**For farms over 1000 cows and Biogas Plant**

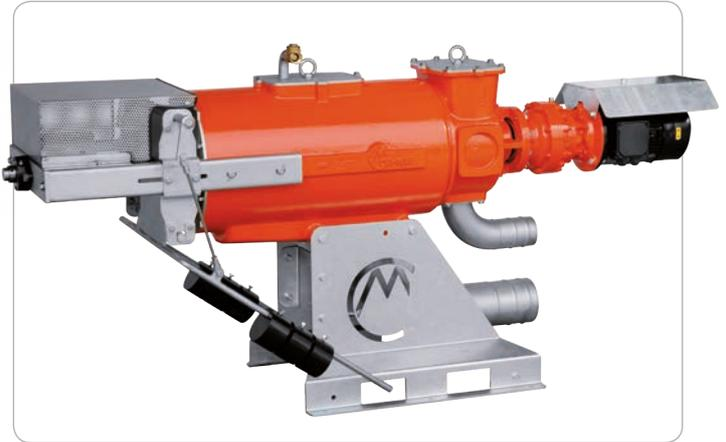

## SM260 DM DRY MATTER SERIES

### Technical specifications:

- Screw in AISI 304 treated stainless steel
  - Front side supported screw
  - Heavy Duty Screen in AISI 316 stainless steel
  - Planetary gear box
  - Sealing system with three lip seals (mechanical seal on request)
- |                |                          |                    |
|----------------|--------------------------|--------------------|
| • Capacity:    | 4 - 22 m <sup>3</sup> /h | 18 - 97 US gpm     |
| • Rpm:         | 14 (50Hz)                | 17 (60Hz)          |
| • Motor power: | 5,5 kW                   | 7,4 HP             |
| • Screen mesh: | 0,50 - 1 mm              | 0,02 - 0,04 inches |
- Up to 37% Dry Matter

**Suitable to obtain a drier solid fraction.  
For farms up to 400 cows**



## SM260FA DM DRY MATTER SERIES

### Technical specifications:

- Screw in AISI 304 treated stainless steel
  - Front side supported screw
  - Heavy Duty main Screen in AISI 316 stainless steel
  - Heavy Heavy Duty Auxiliary Screen in AISI 316 stainless steel
  - Planetary gear box
  - Sealing system with three lip seals (mechanical seal on request)
- |                |                          |                    |
|----------------|--------------------------|--------------------|
| • Capacity:    | 4 - 42 m <sup>3</sup> /h | 18 - 185 US gpm    |
| • Rpm:         | 20 (50Hz)                | 24 (60Hz)          |
| • Motor power: | 7,5 kW                   | 10 HP              |
| • Screen mesh: | 0,50 - 0,75 mm           | 0,02 - 0,03 inches |
- Up to 37% Dry Matter

**Suitable to obtain a drier solid fraction.  
For farms from 300 - 800 cows**



# Plants installed



150 - Italy



50.000 - Russia



500 - Australia



850 - Italy



5.000 - China



150 - Finland



300 - Romania



150 - Italy



6.000 - China



10.000 - Russia



108.000 - Russia



50 - Switzerland



3.000 - Estonia



3.000 - Iran



8.000 - North Korea



# Biogas plant

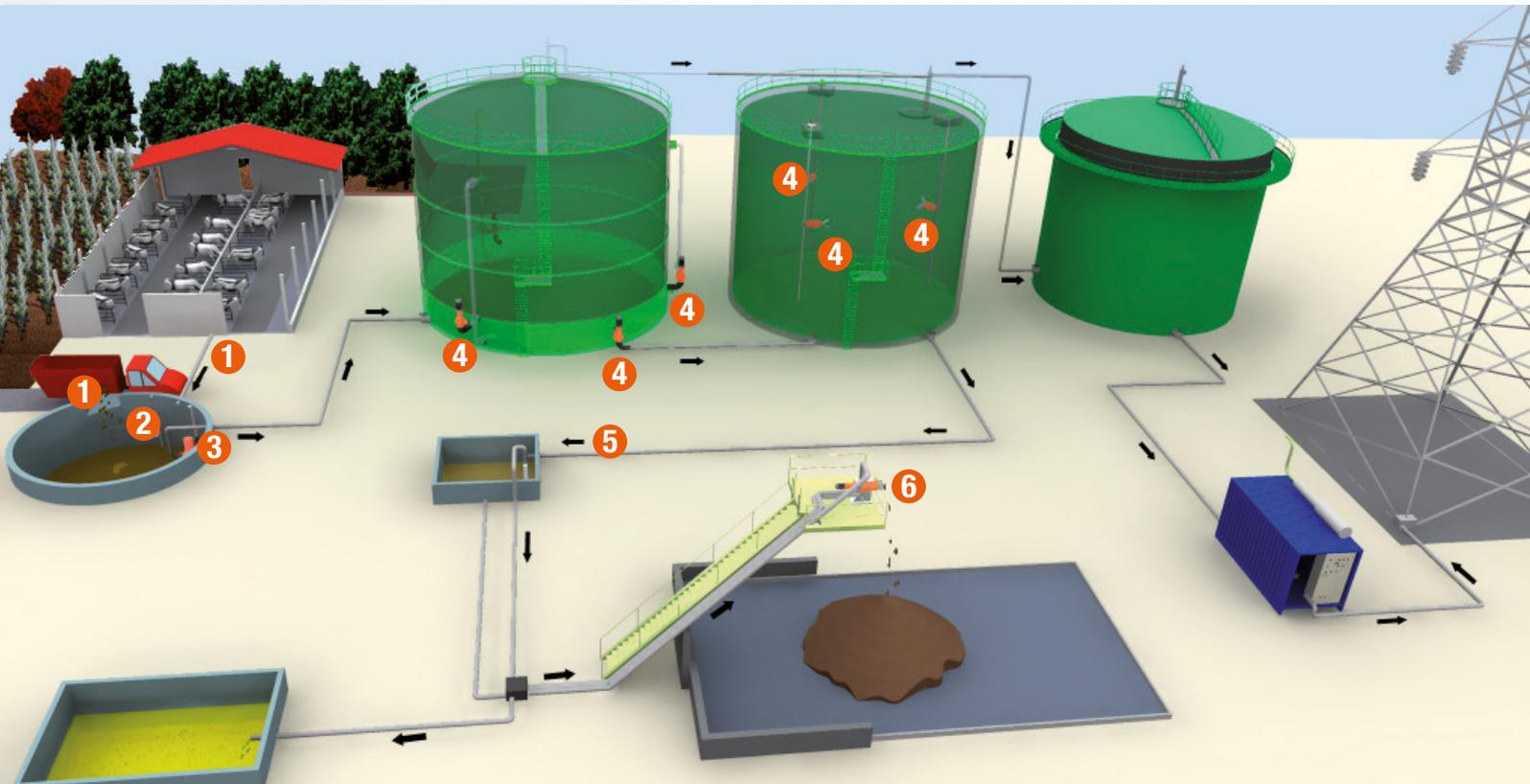

## Application of CRI-MAN products in a typical Biogas plant:

1. Filling feed tank with slurry and/or agricultural waste
2. Mixing feed tank with TBM series submersible mixer
3. Feeding digester with
  - PTS series chopper submersible pump
  - BMC series macerator and PLD series double piston pump
  - CFS series shredder and PLD series double piston pump
4. Mixing digester with
  - TBM series submersible mixer
  - MXB and/or MXL series vertical and/or lateral mixer
  - AF series submersible flow accelerator
  - Nozzle and ETO/ETV series chopper electric pump
5. Transferring substrate into separator feed tank
6. Liquid-solid separation

## Mixers



Submersible mixers are used in digesters to mix and homogenise the substrate, thus increasing the output of the plant and prevent solids settling down which in the long run might reduce the efficiency of the plant, for instance by clogging its pipes.

## Pumps



Motor-driven pumps, both submersible and external, are used to feed the primary digester and/or handle the substrate between digesters and/or for mixing through the nozzles inside the digester. The chopping system provided on all CRI-MAN pumps aids the anaerobic fermentation process, thus improving the efficiency of the plant.

## Separators



Separators are used to separate the solid fraction from the liquid in the anaerobic fermentation process. The liquid fraction can be used as a fertiliser and for irrigation. The solid fraction may be used as an amender, as cattle beds, etc.. Use of separators is also recommended as a pre-treatment in nitrogen-reducing plants.



Check on video

**BIOGAS**





# Pumps

## PTS SERIES

### Submersible chopper pump

#### Technical specifications:

- Double chopping system
- Max capacity: 340 m<sup>3</sup>/h 1497 US gpm
- Head: 45 m 151 ft
- Motor power: 0,75 - 18,5 kW 1 - 26 HP
- Suction: 65 - 200 mm 2 9/16 - 8 inches
- Discharge: 40 - 150 mm 1 9/16 - 6 inches

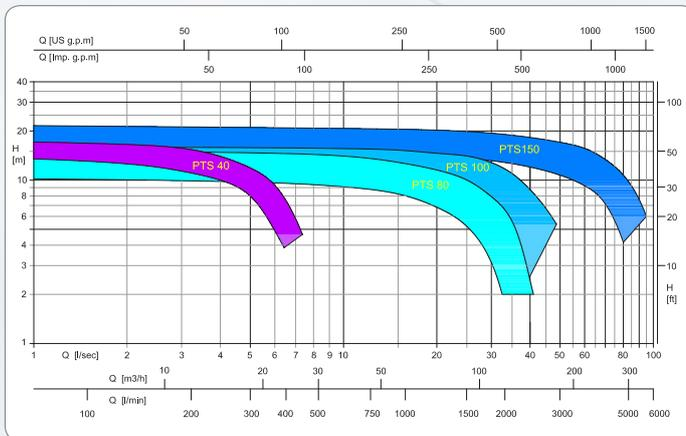

## PLD SERIES

### Pump for high density fluid

Combined with a BMC Macerator it can form a system for maceration, homogenization, and loading for a biogas digester.

It comprises a materials loading tank supplying the double pump pistons and an automatic valve system that permits alternating loading and unloading of the pistons.

#### Technical specifications:

- Hydraulic motor power: 5,5 kW 7,4 HP
- Capacity: 10 - 30 m<sup>3</sup>/h 44 - 132 US gpm
- Head: 80 m 262 ft
- Piston stroke: 900 mm 35,4 inches

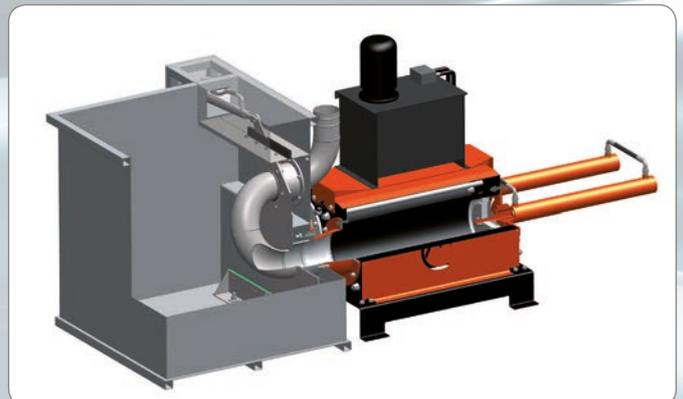

## ETO/ETV SERIES

### Horizontal electric chopper pump

#### Technical specifications:

- Double chopping system
- Max capacity: 340 m<sup>3</sup>/h 1497 US gpm
- Head: 105 m 345 ft
- Motor power: 0,75 - 45 kW 1 - 60 HP
- Suction: 65 - 200 mm 2 9/16 - 8 inches
- Discharge: 40- 150 mm 1 9/16 - 6 inches

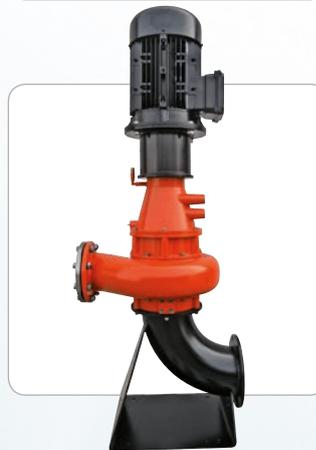
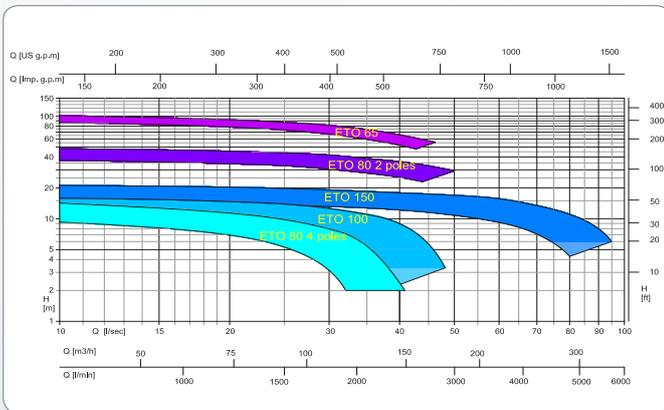

## ETO 200 / EPO 200 SERIES

### Horizontal electric chopper pump

#### Technical specifications:

- ETO version: double chopping system
- EPO version: single chopping system
- Max capacity: 800 m<sup>3</sup>/h 3523 US gpm
- Head: 22 m 72 ft
- Motor power: 22 - 65 kW 29 - 87 HP
- Suction: 250 mm 10 inches
- Discharge: 200 mm 8 inches

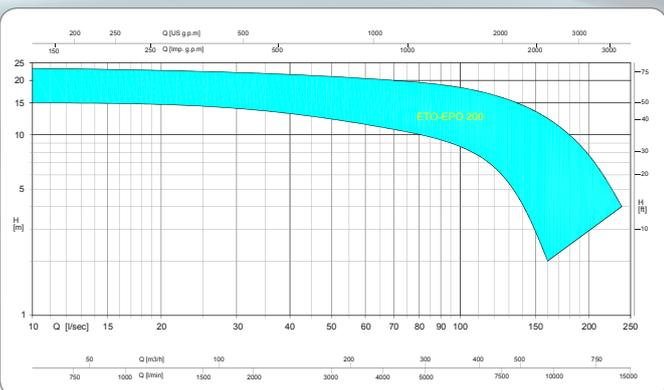



# Mixers

## BMC SERIES

### *Macerator*

Machine for maceration and homogenization of the biomass before entering into the digester. It can be provided with a loading system, which may be a hopper or a conveyor belt, and a discharge system, which may be another conveyor belt or directly to the PLD pump. Available with electric motor or PTO for tractor.

#### Technical specifications:

- Transmission with pulleys and trapezoidal belts
- Hydraulic adjustment system for the holding time of materials inside the macerator
- Level sensors for monitoring the load of solid and/or liquid materials
- Electric motor power: 37 - 55 kW      50 - 74 HP
- Capacity: rpm                      2400 (50 Hz)      2400 (60 Hz)
- Blades in wearproof steel: 10 m<sup>3</sup>/h      44 US gpm



## MXP SERIES

### *Vertical internal mixer*

#### Technical specifications:

- Planetary gearbox
- Inspection porthole with window wiper
- Open tank version: parts in contact with liquid in painted steel
- Digester version (water tight): parts in contact with gas in stainless steel
- Shaft in various lengths
- N. 4 adjustable blades
- Atex II 2G / Ex IIB T4 Gb
- Rpm:                      10 - 15 (50 Hz)      15 - 18 (60 Hz)
- Motor power:                      7,5 - 11 kW      10 - 15 HP



## TBM SERIES

### Submersible horizontal mixer

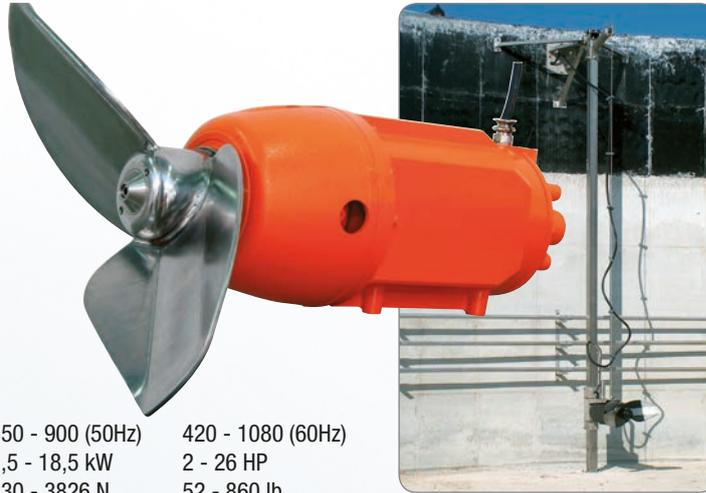

#### Technical specifications:

- Planetary gearbox
  - Blades in stainless steel with self-cleaning profile
- |                     |                              |                     |
|---------------------|------------------------------|---------------------|
| • Rpm:              | 350 - 900 (50Hz)             | 420 - 1080 (60Hz)   |
| • Motor power:      | 1,5 - 18,5 kW                | 2 - 26 HP           |
| • Axial thrust:     | 230 - 3826 N                 | 52 - 860 lb         |
| • Capacity:         | 643 - 6884 m <sup>3</sup> /h | 2831 - 30313 US gpm |
| • Max working temp: | 40 °C                        | 104 °F              |

## AF SERIES

### Submersible horizontal flow accelerator



#### Technical specifications:

- Two-stage planetary gearbox
  - Adjustable blades
  - Blades in polyamide and fibreglass
  - Blades hub in stainless steel
- |                     |                               |                    |
|---------------------|-------------------------------|--------------------|
| • Rpm :             | 53 (50 Hz)                    | 40 (60 Hz)         |
| • Motor power:      | 1,5 - 5,5 kW                  | 2 - 26 HP          |
| • Axial thrust:     | 1226 - 2943 N                 | 276 - 662 lb       |
| • Capacity:         | 11490-17803 m <sup>3</sup> /h | 50590-78380 US gpm |
| • Max working temp: | 40 °C                         | 104 °F             |





# Mixers

## MXB SERIES

### *Vertical external mixer*

#### Technical specifications:

- Planetary gearbox
- 3 vibration dampers
- Automatic lubricator
- Can be adjusted 360°
- Inspection porthole complete with window wiper
- Parts in contact with gas in stainless steel
- Adjustable blades
- Atex II 2G / Ex IIB T4 Gb
- High efficiency (tests compliant with International Standard ISO21630)
- Motor power:           5,5 - 18,5 kW     7,4 - 25 HP
- Rpm                       33 - 45 (50 Hz)    40 - 54 (60 Hz)



## MXL SERIES

### *Lateral external mixer*

#### Technical specifications:

- Planetary gearbox
- Blades in stainless steel with self-cleaning profile
- Rpm                       350 (50 Hz)       420 (60 Hz)
- Motor power           11 - 18,5 kW     15 - 25 HP
- Capacity               3977 - 6884 m<sup>3</sup>/h   17510 - 30309 US gpm
- Axial thrust           2158 - 3826 N     485 - 860 lb
- Max length of shaft   5,5 m             18 ft
- Max working temp.   60°C             140°F



**Patent pending**

# Mixer accessories

## Service box

The service box is used to mount the mixers on the concrete covers of digesters. This solution is perfectly waterproof and can be used to move and rotate the mixer 225° while it works.

In the event of unscheduled maintenance, it allows to take the mixer out of the digester while minimising gas leaks.

In addition, it is provided with an inspection porthole to check the mixer at regular intervals.

Entirely made of AISI 304 stainless steel.



## BioGas bracket

The bracket is used to mount the mixers on the wall and features a system that enables it to move up and down and rotate around the vertical axle. So the location of the mixers and the direction of the flow may be adjusted at any time.

Entirely made of AISI 304 stainless steel.

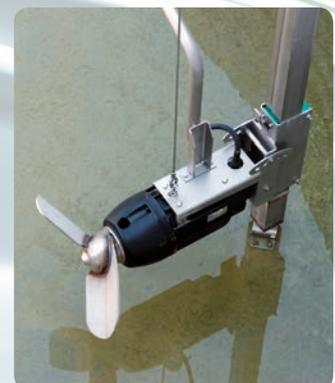
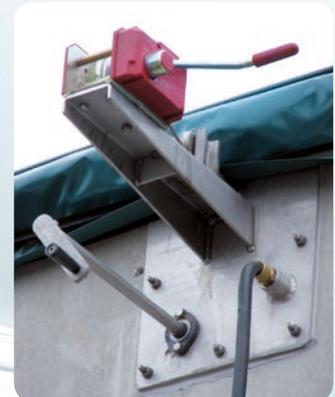



# Separators

## SM260 MINI SERIES

### Technical specifications:

- Screw in AISI 304 treated stainless steel
  - Standard Screen in AISI 316 stainless steel
  - Planetary gear box
  - Sealing system with three lip seals (mechanical seal on request)
- |                |                            |                    |
|----------------|----------------------------|--------------------|
| • Capacity:    | 4,5 - 18 m <sup>3</sup> /h | 20 - 79 US gpm     |
| • Rpm:         | 20 (50Hz)                  | 24 (60Hz)          |
| • Motor power: | 3 kW                       | 4 HP               |
| • Screen mesh: | 0,25 - 1 mm                | 0,01 - 0,04 inches |
- Up to 30% Dry Matter



## SM260 BASIC SERIES

### Technical specifications:

- Screw in AISI 304 treated stainless steel
  - Standard Screen in AISI 316 stainless steel
  - Planetary gear box
  - Sealing system with three lip seals (mechanical seal on request)
- |                |                          |                    |
|----------------|--------------------------|--------------------|
| • Capacity:    | 4 - 50 m <sup>3</sup> /h | 18 - 220 US gpm    |
| • Rpm:         | 33 (50Hz)                | 40 (60Hz)          |
| • Motor power: | 4 kW                     | 5,4 HP             |
| • Screen mesh: | 0,25 - 1 mm              | 0,01 - 0,04 inches |
- Up to 30% Dry Matter



## SM260 PROFESSIONAL SERIES

### Technical specifications:

- Screw in AISI 304 treated stainless steel
  - Front side supported screw
  - Standard Screen in AISI 316 stainless steel
  - Planetary gear box
  - Sealing system with three lip seals (mechanical seal on request)
- |                |                          |                    |
|----------------|--------------------------|--------------------|
| • Capacity:    | 4 - 50 m <sup>3</sup> /h | 18 - 220 US gpm    |
| • Rpm:         | 33 (50Hz)                | 40 (60Hz)          |
| • Motor power: | 4 kW                     | 5,4 HP             |
| • Screen mesh: | 0,25 - 1 mm              | 0,01 - 0,04 inches |
- Up to 30% Dry Matter



## SM300 PROFESSIONAL SERIES

### Technical specifications:

- Screw in AISI 304 treated stainless steel
- Front side supported screw
- Standard Screen in AISI 316 stainless steel (Heavy Duty screen on request)
- Planetary gear box
- Sealing system with three lip seals (mechanical seal on request)

• Capacity:	6 - 72 m <sup>3</sup> /h	26 - 317 US gpm
• Rpm:	33 (50Hz)	40 (60Hz)
• Motor power:	5,5 kW	7,4 HP
• Screen mesh:	0,25 - 1 mm	0,01 - 0,04 inches
• Up to 30% Dry Matter		



## SM260 DM DRY MATTER SERIES

### Technical specifications:

- Screw in AISI 304 treated stainless steel
- Front side supported screw
- Heavy Duty Screen in AISI 316 stainless steel
- Planetary gear box
- Sealing system with three lip seals (mechanical seal on request)

• Capacity:	4 - 22 m <sup>3</sup> /h	18 - 97 US gpm
• Rpm:	14 (50Hz)	17 (60Hz)
• Motor power:	5,5 kW	7,4 HP
• Screen mesh:	0,50 - 1 mm	0,02 - 0,04 inches
• Up to 37% Dry Matter		



## SM260FA DM DRY MATTER SERIES

### Technical specifications:

- Screw in AISI 304 treated stainless steel
- Front side supported screw
- Heavy Duty main Screen in AISI 316 stainless steel
- Heavy Heavy Duty Auxiliary Screen in AISI 316 stainless steel
- Planetary gear box
- Sealing system with three lip seals (mechanical seal on request)

• Capacity:	4 - 42 m <sup>3</sup> /h	18 - 185 US gpm
• Rpm:	20 (50Hz)	24 (60Hz)
• Motor power:	7,5 kW	10 HP
• Screen mesh:	0,50 - 0,75 mm	0,02 - 0,03 inches
• Up to 37% Dry Matter		





# Plants installed

## Italy



50 kW - Italy



1998 kW - Italy



700 kW - Italy



250 kW - Italy



999 kW - Italy



999 kW - Italy



999 kW - Italy



1999 kW - Italy



999 kW - Italy



999 kW - Italy



999 kW - Italy



999 kW - Italy



999 kW - Italy



999 kW - Italy



999 kW - Italy

Abroad



300 kW - Austria



300 kW - Germany



1000 kW - Germany



300 kW - Japan



100 kW - UK



500 kW - Thailand



999 kW - Sweden



500 kW - Germany



500 kW - Germany



500 kW - Germany



500 kW - Holland



5000 kW - Germany



1000 kW - Germany



700 kW - Germany



1000 kW - Germany



# Waste water treatment

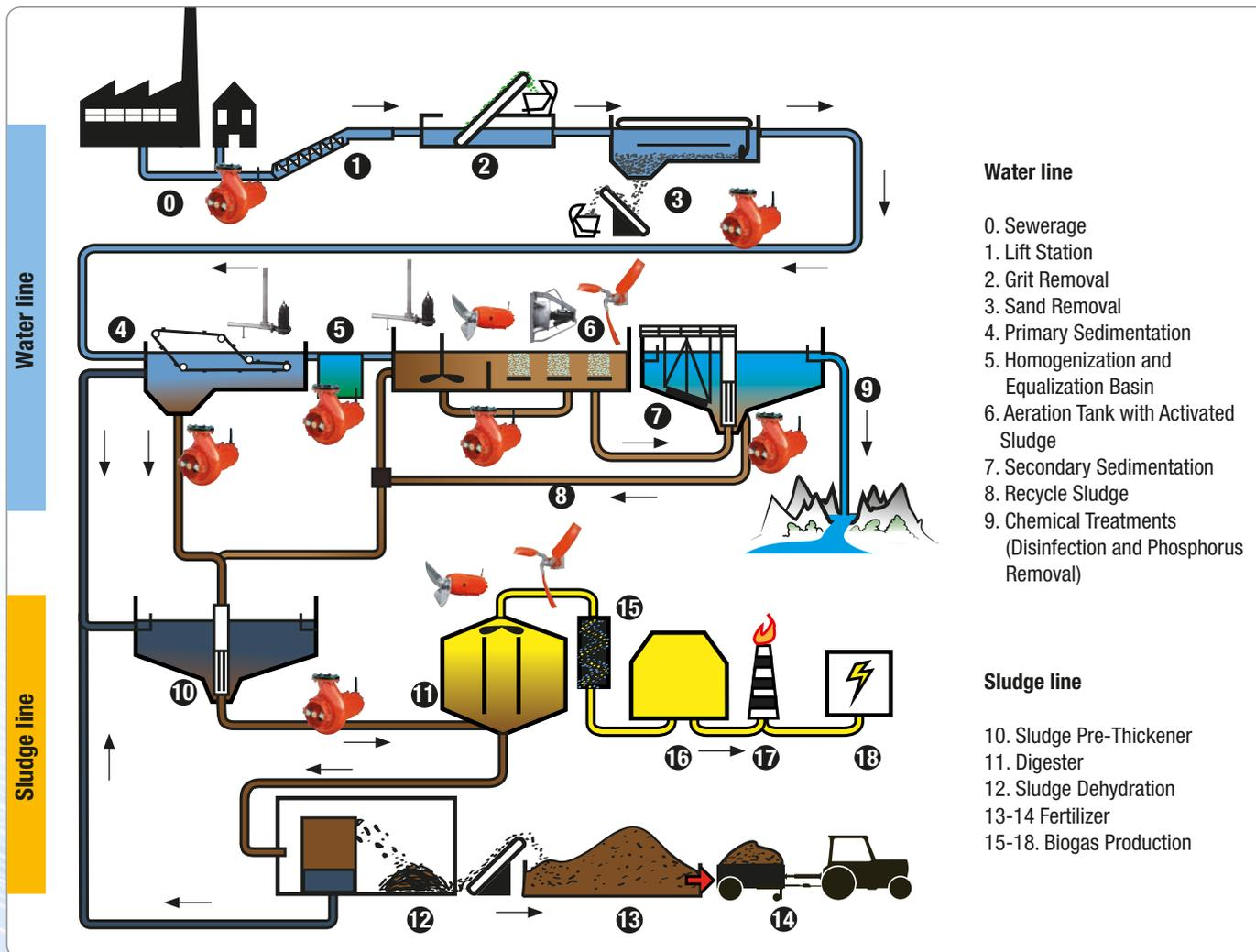

## Waste water treatment process

Cri-Man machines can be used for the following applications in the WWTP.

### PTS, ETO, and ETV Series Pumps

- Drain cleaning hatches. The drainage system can accumulate sediments of considerable bulk which are carried into drain cleaning hatches during rainy periods. The elimination of these is usually achieved using submersible chopper pumps that reduce them into more easily transported elements.
- Tanks for the wheeled removal of industrial effluents. The removal of industrial effluents is achieved using vacuum pumps that extract solid bodies of over 100 mm diameter. Extraction from the collection tank is conducted with chopper pumps.
- Hatches for removal of waste leachate.
- Full biological treatment, in which the transport of the "effluent" is obstructed by the formation of fibrous materials that block the pipes and wind around mixer blades making them unbalanced.

In sections of the plant where effluent transport is required, including:

- Circulation of sludge sediments for denitrification.

- Evacuation of primary and secondary sludge from a decantation tank to a sludge thickener.
- Circulation in anaerobic digesters.
- Transfer to dehydration section.

### ER Series Pumps

- Transfer of liquids between tanks with high capacity and very low pumping head (circulation from nitrification tank to denitrification tank).

### TBM, AF, and TBX Series Mixers

- TBM: small tanks with coarse suspended solids (emptying hatches of various types), small balancing and denitrification tanks, anaerobic digesters (also ATEX version).
- AF: in "Carousel" tanks, sludge digesters.
- TBX: mixers for small tanks including "aggressive" effluents.

### SMO and OXIGET Series Oxygenators

- Oxygenation tanks in small scale plants when it is a priority to avoid plant management problems.

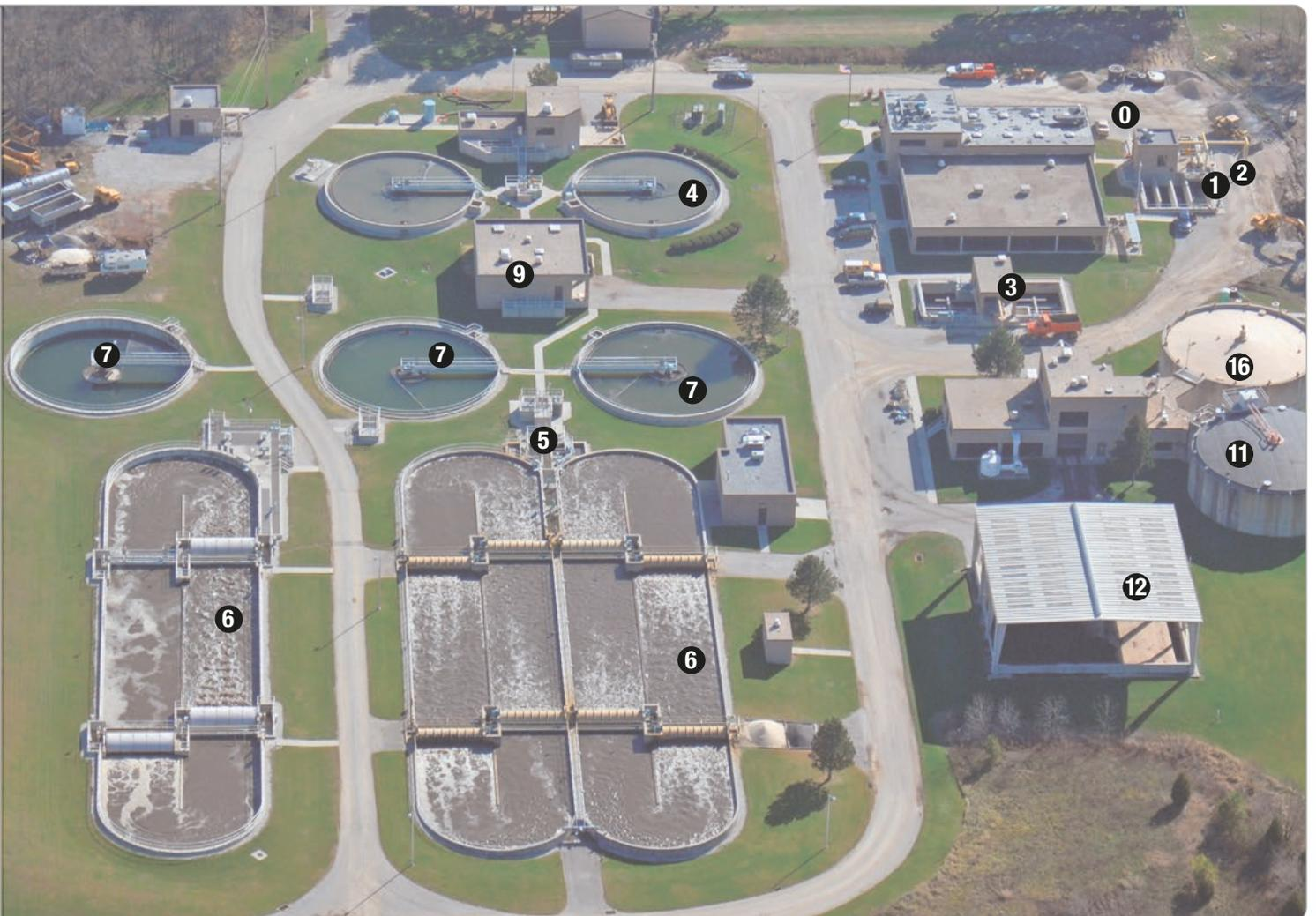

0 3 4



5 6 11



5 6 11



5 6



3



6



5 6 11



Check on video



# Pumps

## ETO/ETV SERIES

### Horizontal electric chopper pump

#### Technical specifications:

- Double chopping system
- Max capacity: 340 m<sup>3</sup>/h 1497 US gpm
- Head: 105 m 345 ft
- Motor power: 0,75 - 45 kW 1 - 60 HP
- Suction: 65 - 200 mm 2 9/16 - 8 inches
- Discharge: 40- 150 mm 1 9/16 - 6 inches

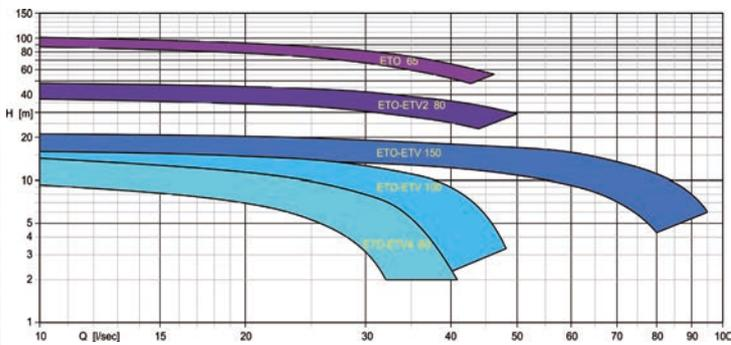

## ETO 200 / EPO 200 SERIES

### Horizontal electric chopper pump

#### Technical specifications:

- ETO version: double chopping system
- EPO version: single chopping system
- Max capacity: 800 m<sup>3</sup>/h 3523 US gpm
- Head: 22 m 72 ft
- Motor power: 22 - 65 kW 29 - 87 HP
- Suction: 250 mm 10 inches
- Discharge: 200 mm 8 inches

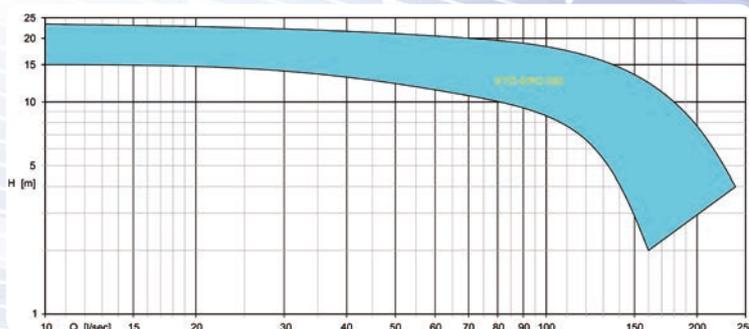

## PTS SERIES

### Submersible chopper pump

#### Technical specifications:

- Double chopping system
- Max capacity: 340 m<sup>3</sup>/h 1497 US gpm
- Head: 45 m 151 ft
- Motor power: 0,75 - 18,5 kW 1 - 26 HP
- Suction: 65 - 200 mm 2 9/16 - 8 inches
- Discharge: 40 - 150 mm 1 9/16 - 6 inches

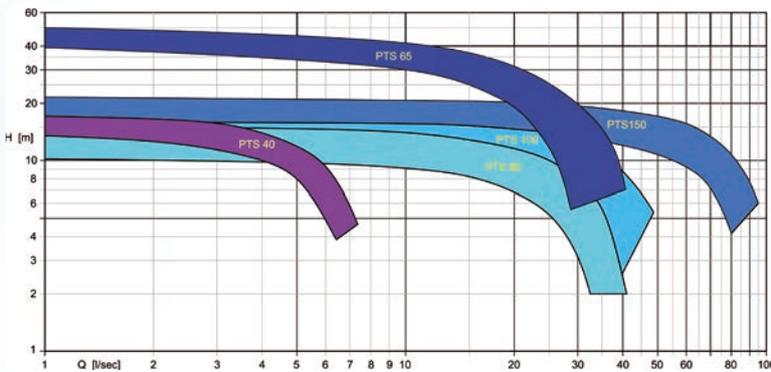

## ER SERIES

### Horizontal axis propeller pump

#### Technical specifications:

- Horizontal axis blades pump with fast delivery coupling system
- Circulation of large volumes of water with excellent hydraulic yield
- Cast iron motor and gearbox, blades and frame in stainless steel
- Capacity: 450 m<sup>3</sup>/h 1980 US gpm
- Head: 1,8 m 5,9 ft
- Motor power: 2,2 - 18,5 kW 3 - 26 HP
- Suction: 500 - 800 mm 19 11/16 - 31 1/2 inches
- Discharge: 500 - 800 mm 19 11/16 - 31 1/2 inches

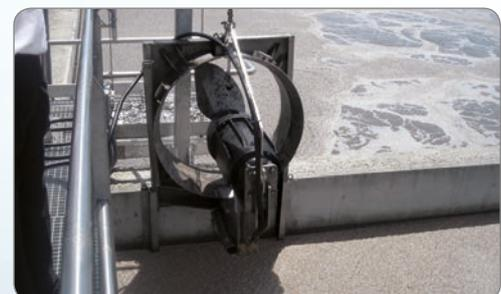
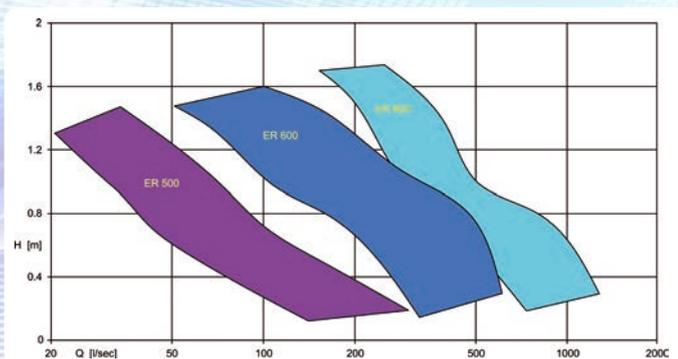
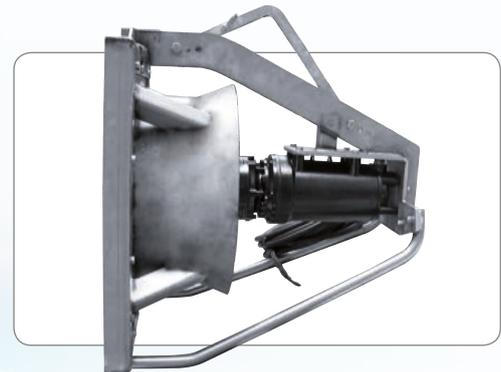



# Mixing tanks

## Large volume tanks:

500 ÷ 4000 m<sup>3</sup> and above

- Wide range of solutions for the
- correct positioning of mixers in relation to the geometry, volume, and type of fluids to be mixed
- Trestle and tripod options for installation without tank side support
- Option of submersed rail guide pipe for regulating the flow height and angle
- Option of combining flow accelerators and traditional mixers in order to optimize mixing and energy consumption

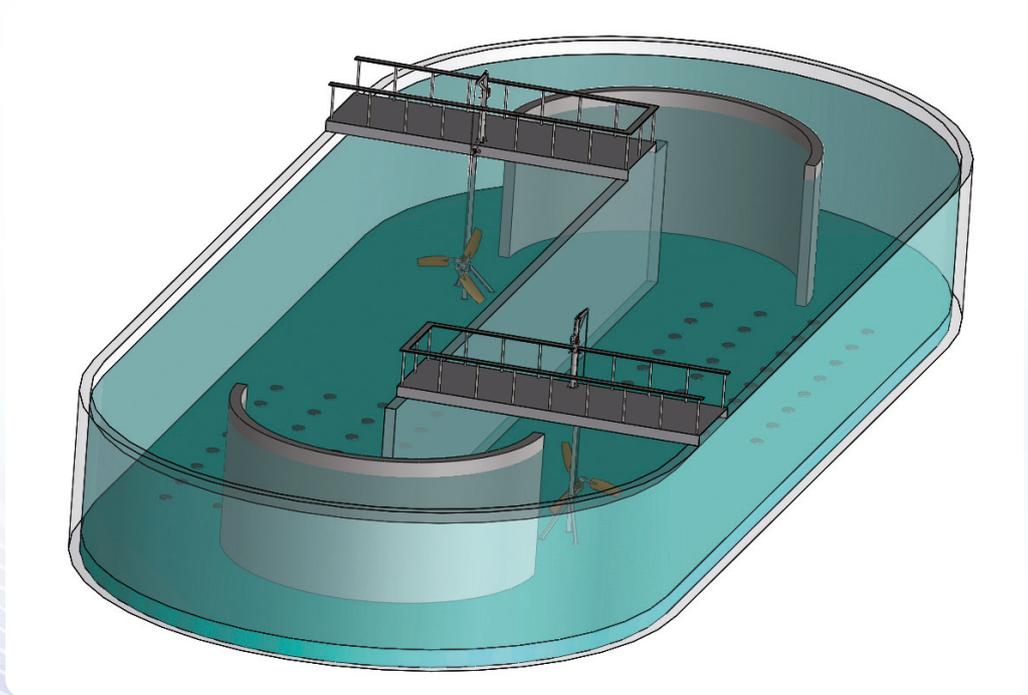

## Small volume tanks:

up to 500 m<sup>3</sup>

- Installation of mixers on submersed rail guide pipe with tank edge or floor hatch fixture
- Installation with suspended pole and the possibility of tilting the flow upwards or downwards
- Fixing structure made entirely in stainless steel
- Equipped with fixtures for crane and winch hoisting

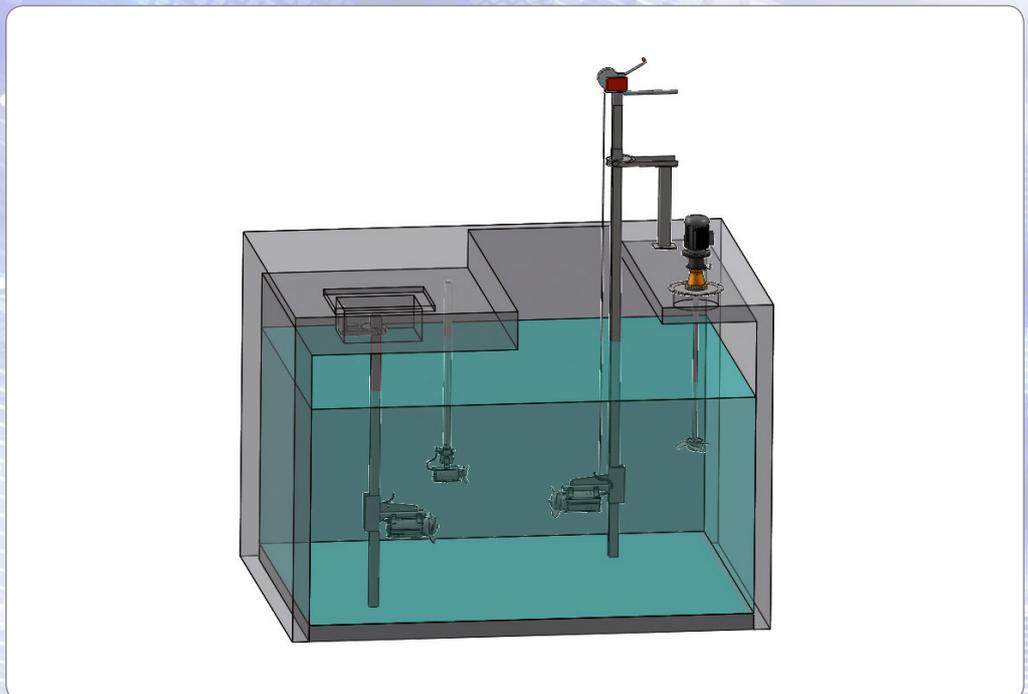

# Mixers

## TBM SERIES

### Submersible horizontal mixer

#### Technical specifications:

- Planetary gearbox
- Blades in stainless steel with self-cleaning profile
- Rpm: 350 - 900 (50Hz) 420 - 1080 (60Hz)
- Motor power: 1,5 - 18,5 kW 2 - 26 HP
- Axial thrust: 230 - 3826 N 52 - 860 lb
- Capacity: 643 - 6884 m<sup>3</sup>/h 2831 - 30313 US gpm
- Max working temp: 40 °C 104 °F



## AF SERIES

### Submersible horizontal flow accelerator

#### Technical specifications:

- Two-stage planetary gearbox
- Adjustable blades
- Blades in polyamide and fibreglass
- Blades hub in stainless steel
- Rpm : 53 (50 Hz) 40 (60 Hz)
- Motor power: 1,5 - 5,5 kW 2 - 26 HP
- Axial thrust: 1226 - 2943 N 276 - 662 lb
- Capacity: 11490-17803 m<sup>3</sup>/h 50590-78380 US gpm
- Max working temp: 40 °C 104 °F





# Mixers

## TBX SERIES

*Stainless steel submersible horizontal mixer*

### Technical specifications:

- Made entirely in stainless steel
- Blades with self-cleaning profile
- Rpm : 900 - 1400                      1100 - 1680
- Motor power: 0,75 - 3 kW              1 - 4 HP
- Axial thrust: 117 - 373 N              26 - 84 lb
- Capacity: 279 -1061 m<sup>3</sup>/h            1128 - 4671 US gpm
- Max working temp: 40 °C              104 °F

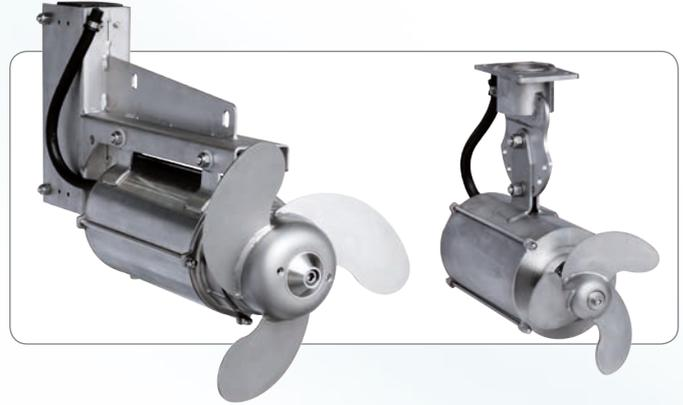

## MXV SERIES

*Vertical mixer with external electric motor*

### Technical specifications:

- Blades in stainless steel wit self-cleaning profile
- Rpm : 900 - 1400                      1100 - 1680
- Motor power: 0,75 - 3 kW              1 - 4 HP
- Axial thrust: 153 - 429 N              26 - 84 lb
- Capacity: 318 -1138 m<sup>3</sup>/h            1128 - 4671 US gpm
- Max working temp: 40 °C              104 °F



# Aerators

## SMO SERIES

### Submersible mixer with external blower

#### Technical specifications:

- Submersible mixer with external blower complete with flow lifting and orienting system
- Submersible mixer power: 11 - 18,5 kW      15 - 25 HP
- External blower motor power: 5,5 kW      7,4 HP
- Liquid mixing capacity: 3900 - 6800 m<sup>3</sup>/h      17170 - 29940 US gpm
- Blown in air capacity: up to 280 m<sup>3</sup>/h      up to 1230 US gpm
- Delivered oxygen capacity: up to 10,5 kg/h      up to 24 lb/h

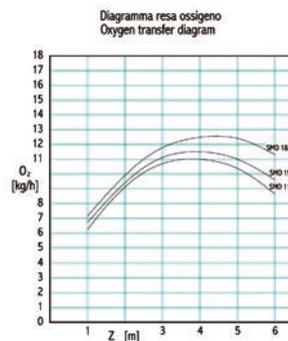
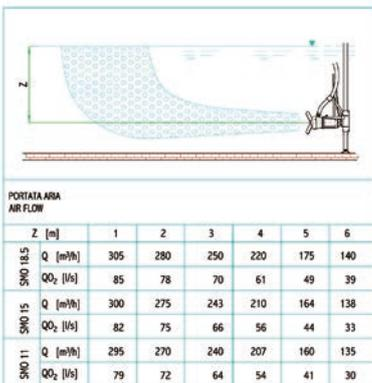

Q = Aria aspirata - Air capacity [m<sup>3</sup>/h]  
Z = Battente - Submergence [m]  
QO<sub>2</sub> = Ossigeno aspirato - Oxygen in air capacity [kg/h]  
O<sub>2</sub> = Ossigeno reso - Oxygen transferred in liquid [kg/h]

Curve per liquidi aventi densità 1-viscosità 1 mm<sup>2</sup>/s - alla temperatura di 20°C.  
Curves established for liquid density 1-viscosity 1 mm<sup>2</sup>/s- temperature 20° C.

## OXIGET SERIES

### Submersible chopper pumps with Venturi tube aerator

#### Technical specifications:

- Combined chopping, mixing, and aeration
- Motor power: 2,2 - 15 kW      3 - 20 HP
- Air suction pipe diameter: 80 - 150 mm      3 1/8 - 6 inches
- Air suction capacity: up to 400 m<sup>3</sup>/h      up to 1760 US gpm
- Delivered oxygen capacity: up to 16,5 kg/h      up to 37 lb/h

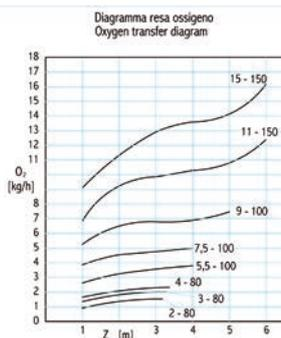
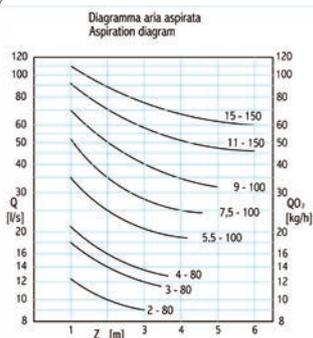

Scelta indicativa Oxiget  
Indicative selection Oxiget

$$P = 0,03 \times V$$

P = Potenza del motore  
Motor rating [kW]

V = Volume liquido vasca  
Volume of liquid sump [m<sup>3</sup>]

Curve per liquidi aventi densità 1-viscosità 1 mm<sup>2</sup>/s - alla temperatura di 20°C.  
Curves established for liquid density 1-viscosity 1 mm<sup>2</sup>/s- temperature 20° C.





# Separators

## SM260 MINI SERIES

### Technical specifications:

- Screw in AISI 304 treated stainless steel
  - Standard Screen in AISI 316 stainless steel
  - Planetary gear box
  - Sealing system with three lip seals (mechanical seal on request)
- |                |                            |                    |
|----------------|----------------------------|--------------------|
| • Capacity:    | 4,5 - 18 m <sup>3</sup> /h | 20 - 79 US gpm     |
| • Rpm:         | 20 (50Hz)                  | 24 (60Hz)          |
| • Motor power: | 3 kW                       | 4 HP               |
| • Screen mesh: | 0,25 - 1 mm                | 0,01 - 0,04 inches |
- Up to 30% Dry Matter



## SM260 BASIC SERIES

### Technical specifications:

- Screw in AISI 304 treated stainless steel
  - Standard Screen in AISI 316 stainless steel
  - Planetary gear box
  - Sealing system with three lip seals (mechanical seal on request)
- |                |                          |                    |
|----------------|--------------------------|--------------------|
| • Capacity:    | 4 - 50 m <sup>3</sup> /h | 18 - 220 US gpm    |
| • Rpm:         | 33 (50Hz)                | 40 (60Hz)          |
| • Motor power: | 4 kW                     | 5,4 HP             |
| • Screen mesh: | 0,25 - 1 mm              | 0,01 - 0,04 inches |
- Up to 30% Dry Matter



## SM260 PROFESSIONAL SERIES

### Technical specifications:

- Screw in AISI 304 treated stainless steel
  - Front side supported screw
  - Standard Screen in AISI 316 stainless steel
  - Planetary gear box
  - Sealing system with three lip seals (mechanical seal on request)
- |                |                          |                    |
|----------------|--------------------------|--------------------|
| • Capacity:    | 4 - 50 m <sup>3</sup> /h | 18 - 220 US gpm    |
| • Rpm:         | 33 (50Hz)                | 40 (60Hz)          |
| • Motor power: | 4 kW                     | 5,4 HP             |
| • Screen mesh: | 0,25 - 1 mm              | 0,01 - 0,04 inches |
- Up to 30% Dry Matter



## SM300 PROFESSIONAL SERIES

### Technical specifications:

- Screw in AISI 304 treated stainless steel
- Front side supported screw
- Standard Screen in AISI 316 stainless steel (Heavy Duty screen on request)
- Planetary gear box
- Sealing system with three lip seals (mechanical seal on request)

• Capacity:	6 - 72 m <sup>3</sup> /h	26 - 317 US gpm
• Rpm:	33 (50Hz)	40 (60Hz)
• Motor power:	5,5 kW	7,4 HP
• Screen mesh:	0,25 - 1 mm	0,01 - 0,04 inches
• Up to 30% Dry Matter		

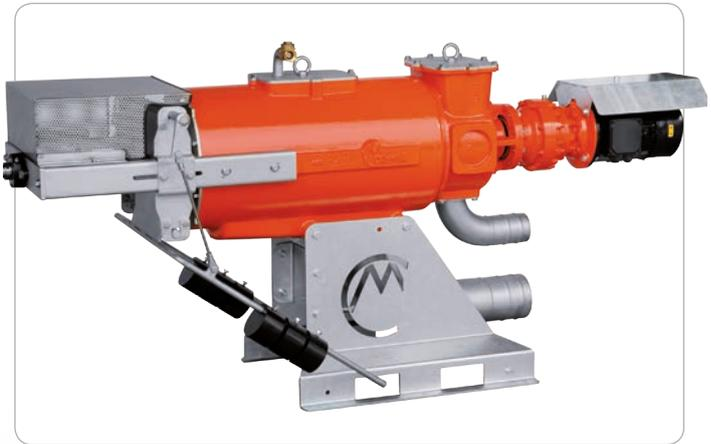

## SM260 DM DRY MATTER SERIES

### Technical specifications:

- Screw in AISI 304 treated stainless steel
- Front side supported screw
- Heavy Duty Screen in AISI 316 stainless steel
- Planetary gear box
- Sealing system with three lip seals (mechanical seal on request)

• Capacity:	4 - 22 m <sup>3</sup> /h	18 - 97 US gpm
• Rpm:	14 (50Hz)	17 (60Hz)
• Motor power:	5,5 kW	7,4 HP
• Screen mesh:	0,50 - 1 mm	0,02 - 0,04 inches
• Up to 37% Dry Matter		



## SM260FA DM DRY MATTER SERIES

### Technical specifications:

- Screw in AISI 304 treated stainless steel
- Front side supported screw
- Heavy Duty main Screen in AISI 316 stainless steel
- Heavy Heavy Duty Auxiliary Screen in AISI 316 stainless steel
- Planetary gear box
- Sealing system with three lip seals (mechanical seal on request)

• Capacity:	4 - 42 m <sup>3</sup> /h	18 - 185 US gpm
• Rpm:	20 (50Hz)	24 (60Hz)
• Motor power:	7,5 kW	10 HP
• Screen mesh:	0,50 - 0,75 mm	0,02 - 0,03 inches
• Up to 37% Dry Matter		





## Other applications

### PTSH SERIES

*Submersible centrifugal pump with hydraulic motor control*

#### Technical specifications:

- Multi channel impeller
- Double chopping system
- Fixed installation with hydraulic unit, or on self-moving arm controlled with a hydraulic circuit
- Capacity: 380 m<sup>3</sup>/h 1670 US gpm
- Head: 26 m 85 ft
- Hydraulic oil capacity: max 48 l/min max 13 l/gpm
- Hydraulic oil pressure: max 316 bar max 4598 psi

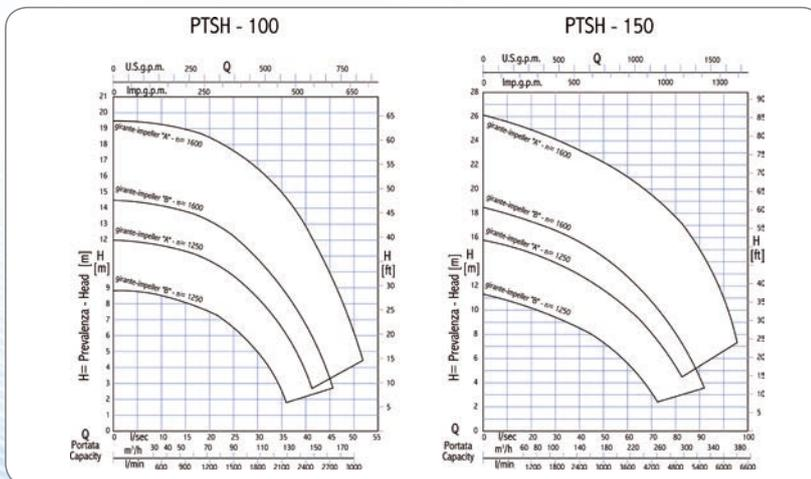

### TBHM SERIES

*Submersible mixer with hydraulic motor control*

#### Technical specifications:

- Impeller: stainless steel with self cleaning profile
- Fixed installation with hydraulic unit, or on self-moving arm controlled with a hydraulic circuit
- Axial thrust: 850 - 3800 N 191 - 854 lb
- Hydraulic oil capacity: max 90 l/min 24 US gpm
- Hydraulic oil pressure: max 130 bar 1884 psi



# Plants installed



WWTP - Italy



WWTP - Italy



WWTP - Sweden



WWTP - France



WWTP - Italy



WWTP - Italy



WWTP - France



WWTP - Germany



WWTP - Spain



Abattoir - Italy



Salad - Italy



Coffee - Germany



Corn - Russia



Pulp and paper - Sweden



Brewery - Russia

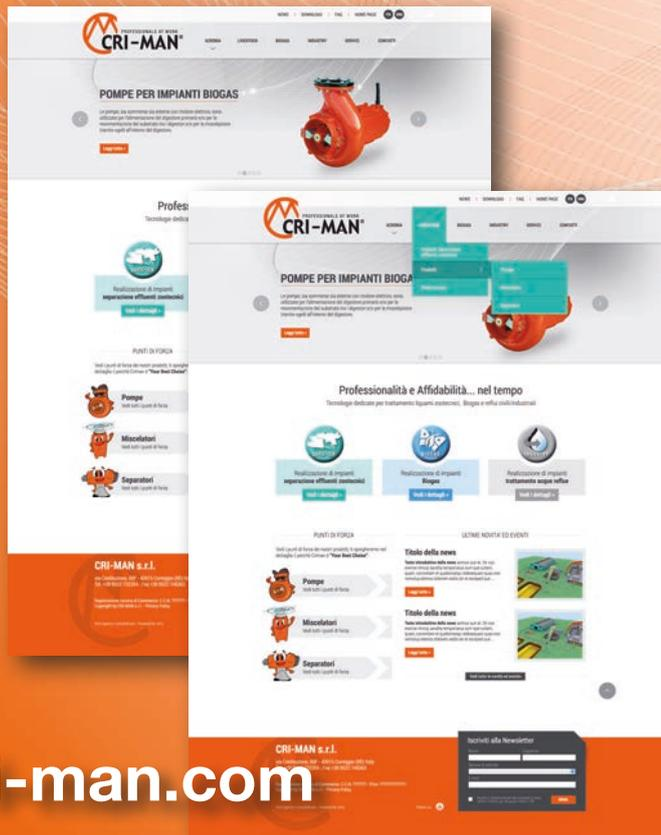

[www.cri-man.com](http://www.cri-man.com)



**CRI-MAN s.r.l.** - via Costituzione, 50F  
 42015 CORREGGIO (RE) Italy  
 Tel. +39 0522 732204 - Fax +39 0522 746363  
 email: [info@cri-man.com](mailto:info@cri-man.com) - [www.cri-man.com](http://www.cri-man.com)

